

APX 7000

Service Instructions



Copyright by Carl Valentin GmbH / 7997525.0321

Information on the scope of delivery, appearance, performance, dimensions and weight reflect our knowledge at the time of printing.

We reserve the rights to make modifications.

All rights, including those regarding the translation, are reserved.

No part of this document may be reproduced in any form (print, photocopy or any other method) or edited, copied or distributed electronically without written permission from Carl Valentin GmbH.

Due to the constant further development of our devices discrepancies between manual and device can occur.

Please check www.carl-valentin.de for the latest update.

Trademarks

All named brands or trademarks are registered brands or registered trademarks of their respective owners and may not be separately labelled. It must not be concluded from the missing labelling that it is not a registered brand or a registered trademark.

Carl Valentin print modules comply with the following safety guidelines:

CE Electromagnetic Compatibility Directive (2014/30/EU)
EG Machinery Directive (2006/42/EG)



Carl Valentin GmbH

Postfach 3744
78026 Villingen-Schwenningen
Neckarstraße 78 – 86 u. 94
78056 Villingen-Schwenningen

Phone +49 7720 9712-0
Fax +49 7720 9712-9901

E-Mail info@carl-valentin.de
Internet www.carl-valentin.de

Table of Contents

1	Notes on this Document	5
1.1	User Notes	5
1.2	Instructions	5
1.3	Cross References	6
2	Safety Instructions	7
2.1	General Safety Instructions	7
2.2	Safety Marking	9
3	Product Description	11
3.1	Applicator Overview	11
3.2	Sensor	14
3.3	Pneumatic.....	15
4	Maintenance and Cleaning	19
4.1	Tools.....	19
4.2	Cleaning.....	20
5	Replacing Components	21
5.1	Remove the Covers.....	21
5.2	Stick the Slide Foil onto the Pad.....	22
5.3	Replace the Valves	23
5.4	Replace the PCB.....	24
5.5	Replace the Cylinder	25
5.6	Replace the Sensors at the Cylinder.....	26
6	Refit the Options	29
6.1	'Quick Apply'	29
6.2	Shock Absorber.....	30
7	Troubleshooting.....	31
7.1	Sensor Labelling Position / Sensor Start Position.....	31
7.2	Supporting Air Throttle Pressure Measuring	32
7.3	Vacuum Throttle Pressure Measuring.....	33
7.4	Pressure Control/Vacuum Control Adjustment.....	34
7.5	Error Indications.....	36
8	Wiring Plan	39
9	Pneumatic Plan	41
10	Connector Pin Assignment of PCB	43
11	Environmentally-Friendly Disposal	45
12	Index	47

1 Notes on this Document

1.1 User Notes

This service manual is intended for qualified service and maintenance staff.

This manual contains information about the applicator APX 7000.

Information about operation of the print module can be taken from our operating manual.

If a problem arises that cannot be solved with the help of this service instructions, then please contact your responsible dealer.

1.2 Instructions

Basic information and warning references with the corresponding signal words for the danger level are as follows specified in this manual:



DANGER identifies an extraordinarily great and immediate danger which could lead to serious injury or even death.



WARNING identifies a possible danger would could lead to serious bodily injury or even death if sufficient precautions are not taken.



WARNING of cutting injuries.

Pay attention that cutting injuries caused by blades, cutting devices or sharp-edged parts are avoided.



WARNING of hand injuries.

Pay attention that hand injuries caused by closing mechanical parts of a machine/equipment are avoided.



WARNING of hot surfaces.

Pay attention so as not to come into contact with hot surfaces.



CAUTION indicates a potentially dangerous situation which could lead to moderate or light bodily injury or damage to property.



NOTICE gives you tips. They make a working sequence easier or draw attention to important working processes.



Gives you tips on protecting the environment.



Handling instruction



Optional accessories, special fittings

Date

Information in the display

1.3 Cross References

Drawings

References to specific items in a figure are marked with letters. They are identified with parentheses in the text, e.g. (A). If no figure number is provided, letters in the text always refer to the graphic directly above the text. If a reference is made to another graphic, the figure number is specified, e.g. (A, in figure 5).

Cross references to chapters and sections

For a cross reference to chapters and sections, the chapter number and page number are specified, e.g. a reference to this section: see chapter 1.3.2, page 35).

References to other documents

References to other documents have the following form: See '*operating manual*'.

2 Safety Instructions

2.1 General Safety Instructions

Workplace and method of working

- ⇒ Keep the area around the applicator clean during and after maintenance.
- ⇒ Work in a safety-conscious manner.
- ⇒ Store dismantled device parts in a safe place while maintenance is being performed.

Clothing



CAUTION!

The drawing in of items of clothing by moving parts can lead to injuries.

- ⇒ If possible, do not wear clothing which could be caught by moving device parts.
- ⇒ Button or roll up shirt or jacket sleeves.
- ⇒ Tie or pin up long hair.
- ⇒ Tuck the ends of scarves, ties and shawls into your clothing or secure them with non-conductive clips.



DANGER!

Risk of death from increased flow of current via metals parts which come into contact with the device.

- ⇒ Do not wear clothing with metal parts.
- ⇒ Do not wear jewellery.
- ⇒ Do not wear glasses with a metal frame.

Protective clothing

If a possible danger to your eyes is present, wear protective goggles, especially in the following cases:

- when knocking in or knocking out pins and similar parts with a hammer
- when using an electric drill
- when using spring hooks
- when loosening or inserting springs, snap rings and gripping rings
- when soldering
- when using solvents, cleaning agents or other chemicals

Protective equipment**WARNING!**

Risk of injury in case of missing or faulty protective equipment.

- ⇒ After performing maintenance work, attach all safety equipment (covers, safety precautions, ground cables etc.).
- ⇒ Replace the faulty parts and those which have become unusable.

General safety instructions

Before mounting the delivered components disconnect the printing system from the power supply and close the shutoff valve at the applicator.

Couple the applicator to devices using extra low voltage only.

Before making or undoing connections, switch off all devices involved (computer, printer, accessories etc.).

In operation, moving parts are easily accessible. This applies especially for the zone, where the pad is moved between the starting and the labelling position. During operation do not reach into that zone and keep long hair, loose clothes, and jewellery distant.

Before any manipulations in those areas, close the shutoff valve.

Operate the applicator in a dry environment only and do not get it wet (sprayed water, mist etc.).

Do not operate the applicator in explosive atmosphere and not in proximity of high voltage power lines.

Operate the applicator only in an environment protected against abrasive dust, swarf and other similar impurity.

**NOTICE!**

With the open printing unit (due to construction) the requirements of EN 62368-1 regarding fire protection casing are not fulfilled. These must be ensured by the installation into the end device.

Maintenance and servicing work can only be carried out by trained personnel.

Operating personnel must be trained by the operator on the basis of the operating manual.

Carry out only the actions described in these operating instructions. Any work beyond this may only be performed by specially trained personnel or service technicians.

Unauthorized interference with electronic modules or their software can cause malfunctions.

Other unauthorized work or modifications to the applicator can endanger operational safety.

There are warning stickers on the applicator that draw your attention to dangers. Therefore the warning stickers are not to be removed as then you and others cannot be aware of dangers and may be injured.

When incorporating the unit into the overall system, make sure that safety precautions are taken so that no-one is able to reach into the working area.

**CAUTION!**

Damages of the plunger rod, cylinder tube or the seals caused by lateral forces that affect the plunger rod of the cylinder. This can lead to a reduction of lifetime and to leakages up to destruction of the cylinder.

⇒ Lateral forces must be avoided necessarily.

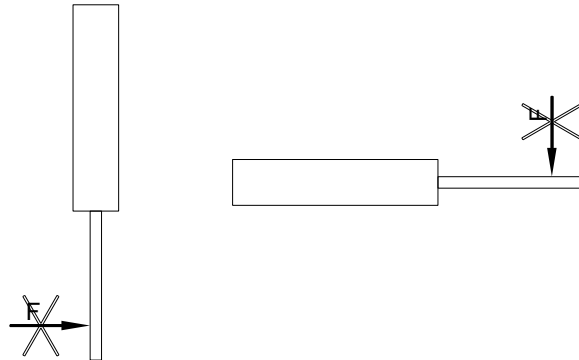
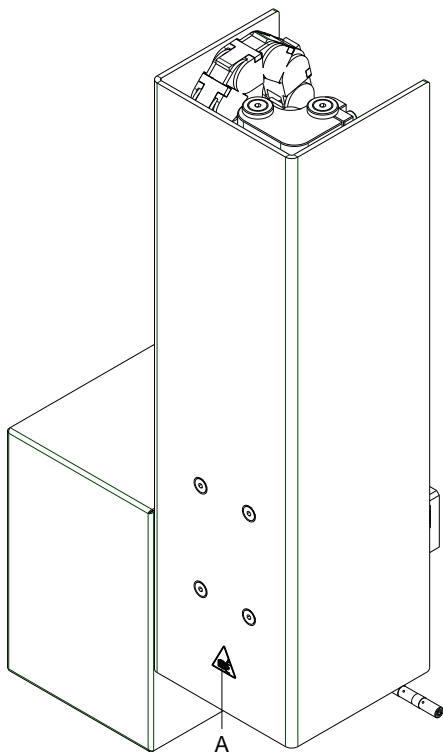
**2.2 Safety Marking**

A = Risk of crushing due to the movement of the pad

**CAUTION!**

There is a risk of injury due to the movement of the pad downwards and back up again.

- ⇒ Do not reach into the working area of the pad.
- ⇒ Keep hair, loose clothing and items of jewellery out of this area.
- ⇒ When incorporating the unit into the overall system, safety precautions must be taken so that no-one is able to reach into the working area.

Figure 1

3 Product Description

3.1 Applicator Overview

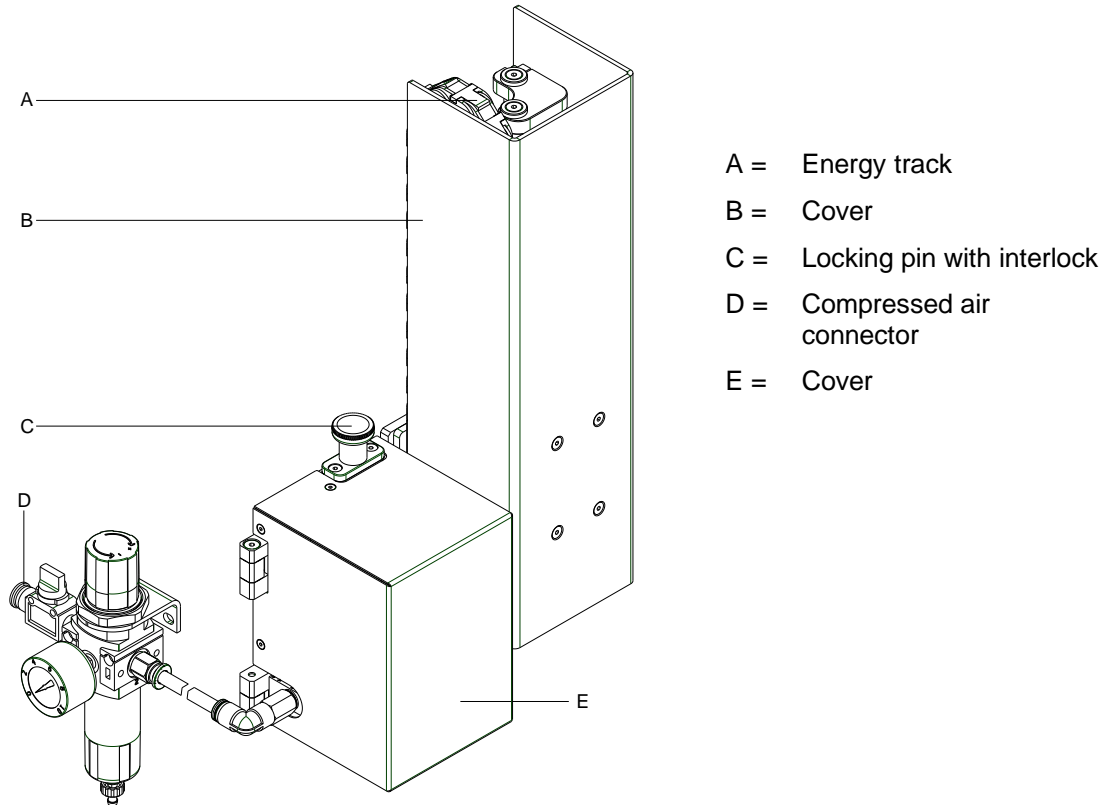

Figure 2

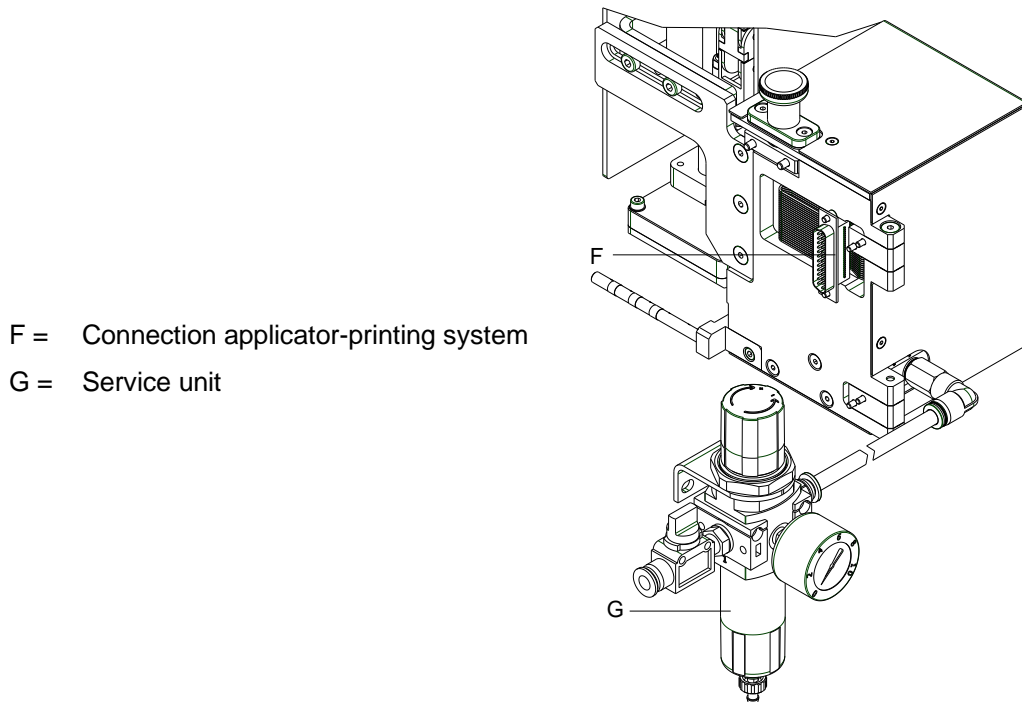

Figure 3

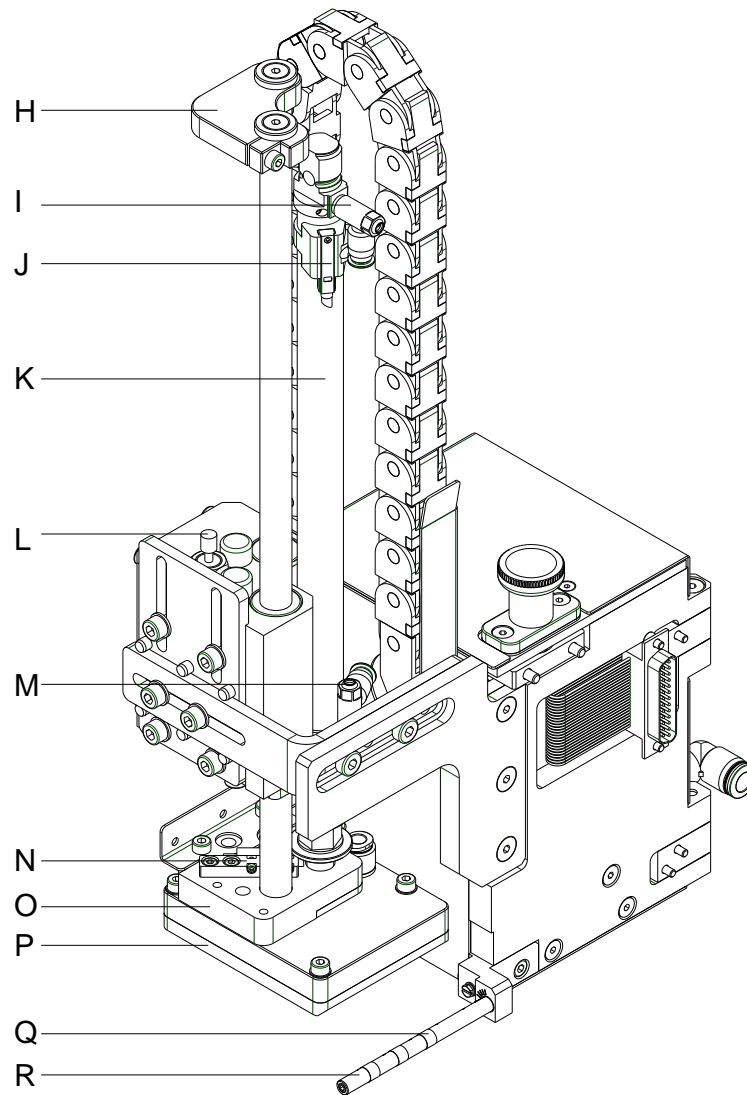

Figure 4

- H = Stopper
- I = Throttling back valve 'cylinder' (top)
- J = Sensor top end position
- K = Stroke cylinder
- L = Shock absorber (option)
- M = Throttling back valve 'cylinder' (bottom)
- N = Sensor bottom end position
- O = Pad retainer
- P = Pad
- Q = Plastic ring
- R = Supporting air tube

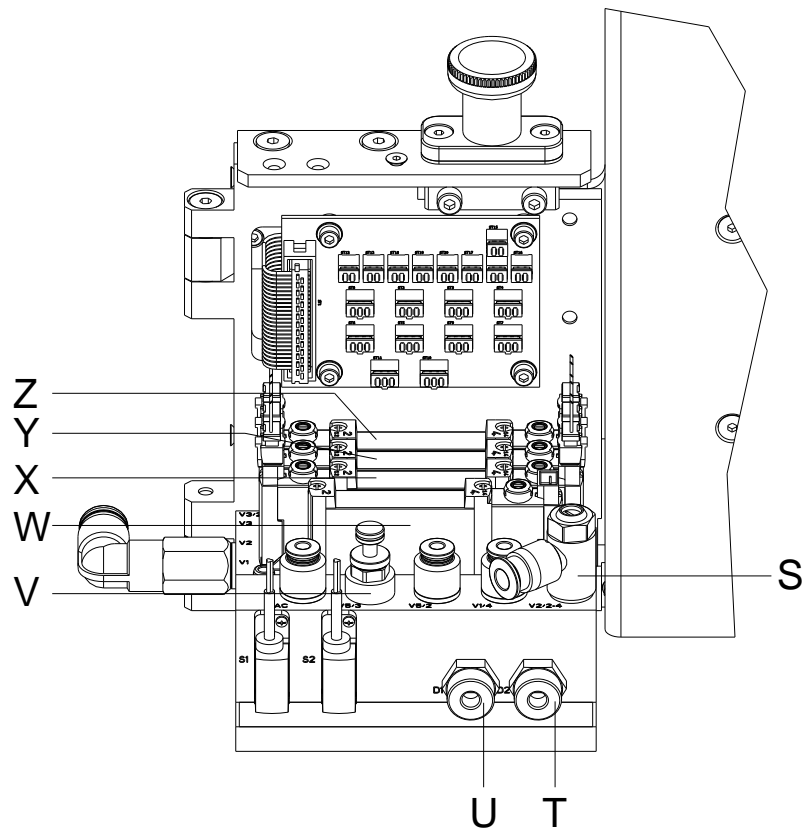

Figure 5

- S = Throttling valve blowing air
- T = Throttling valve vacuum
- U = Throttling valve supporting air
- V = Throttle 'Quick Apply' (option)
- W = Valve 'Quick Apply' (option)
- X = Valve stroke cylinder
- Y = Valve blowing air
- Z = Valve vacuum/supporting air

3.2 Sensor

Sensor labelling position

The impact of the pad on the product and the reaching of the blow-off position are detected by means of an inductive proximity switch and a spring-mounted cam disc. The distance between the cam disc and the inductive proximity switch is used.

Sensor start position

The start position is the upper end position of cylinder and the position of the pad which takeover the label from printer. This position will be detected via a Reed-sensor in interaction with a magnet mounted inside cylinder.

Sensor vacuum

The correct transfer of a label will be checked by the vacuum sensor. It also checks that there is no longer a label on the pad in case of the return movement. This sensor is integrated to the APX connection PCB.

Sensor pressure

The pressure sensor controls the pressure air. This sensor is integrated to the APX connection PCB.

3.3 Pneumatic

Cylinder	<p>A cylinder with stroke of 100 ... 500 mm is used for the transport of labels between the peel-off edge of the printer and the labelling position. The movement of cylinder is controlled by a control valve on the valve block.</p> <p>The speed of movement can be changed by two throttle valves mounted at the cylinder.</p>
Pad	<p>The label will be transported by a pad. The pad must be appropriate to the size of label.</p> <p>During the label transport a vacuum is applied on the pad.</p> <p>In operating mode 'blow on' in the lower final position the label is applied by a high pressure.</p>
Vacuum generator	<p>The vacuum at the pad is produced by a vacuum generator. The vacuum generator is controlled by control valve on the valve block.</p> <p>The low pressure can be adjusted by a throttle valve.</p>
Blow tube	<p>Air is blown from below (supporting air) through a blow tube onto the label in order to support the transfer of the label from the printer to the pad. The blow tube is adjustable concerning the blowing direction.</p> <p>The supporting air is connected by the magnet valve (support air). The power of the supporting air can be adjusted by a throttle valve at the valve block.</p>
Pneumatic maintenance unit	<p>The pneumatic maintenance unit is offered as an option for the applicator. The important components of the pneumatic maintenance unit are a pressure reducer with manometer, a water separator with micro filter and a main connector for compressed air.</p>
Valve block	<p>The distribution of the compressed air to the various pneumatic units is made in the valve block.</p> <p>On the valve block is mounted the control valve for support air and vacuum with their throttle valves and the control valves for the lift cylinder and blow air.</p>

Control valves

**NOTICE!**

For adjustments of certain applicator functions, release the control valves in the pneumatic system. The control valves are accessible only with dismantled protective covers for the electronics and cylinder.

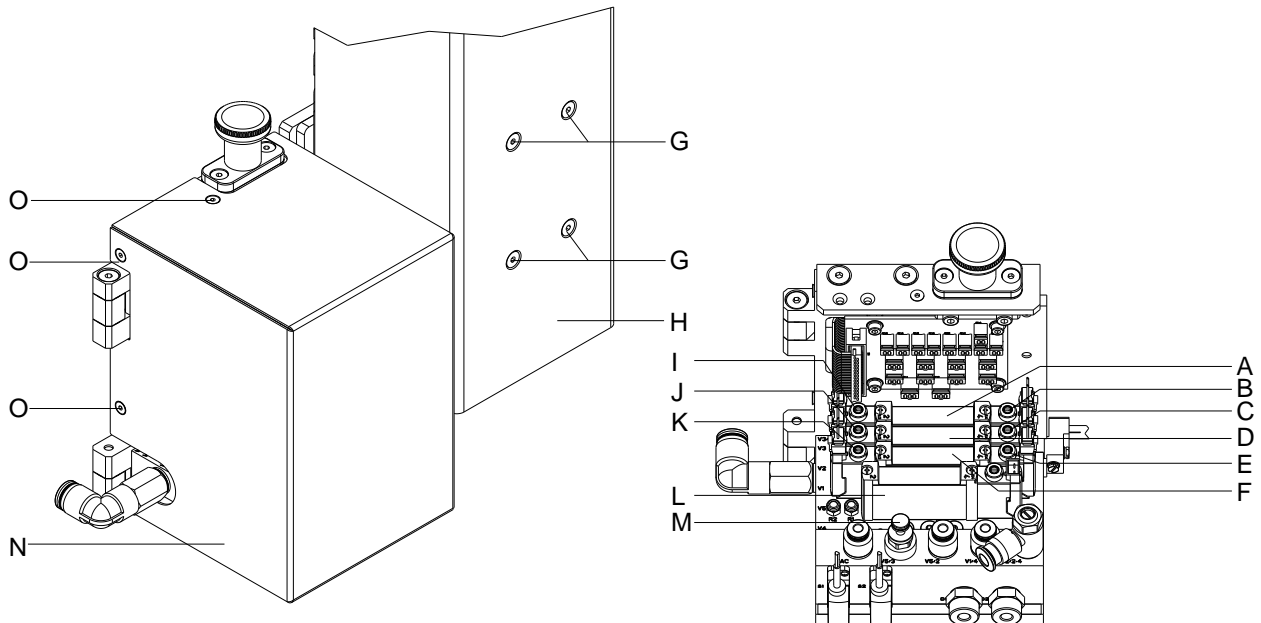

Figure 6

1. Loosen the screws (O) and remove the electronics' cover (N).
2. The compressed air control valves can be controlled manually with integrated switch (E-K, C-J, B-I).

3-way valve (F) to control the lift cylinder

If the printer is switched on the valve will be controlled by electronics and the tamp will hold in the upper end position (home position). If the valve is switched the tamp will move in the lower end position (labelling position). In normal labelling operation the movement back in the upper end position will start by a signal from the labelling sensor.

**NOTICE!**

The switching by hand of this valve has only a result in case of a switched off printer.

Switching the valve by hand over switch (E) the tamp will move down up to the lowest possible position because no control is made by the sensor.

Switching the valve by hand over switch (K) the tamp will move up.

**Double 2-way valve (D)
for blowing air**

In the operation mode 'Blow on' the label will blow up to the product.

In the operating modes 'Stamp on' and 'Roll on' the blow air is switched on for a short time after each application to avoid contaminations within the vacuum channels.

For all described functions both valves will be controlled parallel.

By pressing the keys (C) or (J) the blow air is only switched on by one of both internal valves.

**Double 2-way valve (A)
for vacuum /
supporting air**

The two internal valves serve the vacuum nozzle for connecting an in this way for creating the negative pressure at the tamp and independent of this for connecting the support air at the blow tube for the label transfer.

By pressing switch (B) the vacuum is switched on and by pressing switch (I) the supporting air is switched on.

**2-way valve (A) for
option 'Quick Apply'**

Figure 7

Turn the adjusting screw (B) to set the absorption of solenoid valve (A).

In the "quick apply" menu of the printing system, set the desired delay for valve activation in ms.

4 Maintenance and Cleaning

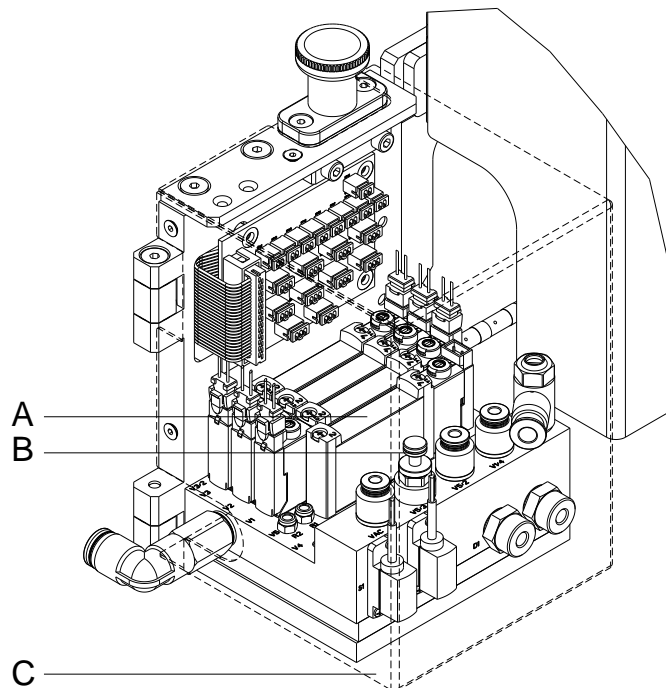
4.1 Tools

For Assemblies	Tools	Size
Cylinder plunger	Spanner wrench	5,0 mm
Throttling valves cylinder		8,0 mm
Throttling valve vacuum, blowing air		12,0 mm
L-connector, cam disk (valve block in service unit)		14,0 mm
Lift cylinder		22,0 mm
Valve block, energy track	Hexagon wrench	2,0 mm
PCB		2,5 mm
Adjustment guiding block		4,0 mm
Throttle valves	Screwdriver for slotted screws	2,5 mm
Valves on the valve block	Crosstip screwdriver	PH 0
Sensors (labelling sensor + sensor start position)		PH 2
Works at PCB	Wrist grounding	
Pressure measurement	Manometer	to approx. 5 bar
Cloth soft brush, multi-purpose cleaner (without solvent)		

4.2 Cleaning



CAUTION!

Abrasive cleaning agents can damage the applicator!

⇒ Do not use abrasives or solvents to clean the outer surface of the label printer.

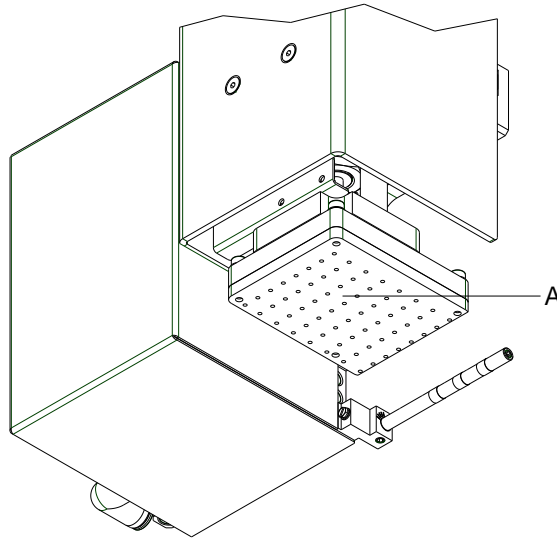

Figure 8

Clean the outside surfaces with multipurpose cleaner.

Remove dust particles and label splits with a soft brush or a vacuum cleaner.

The ideal takeover and handling of the label can be achieved by cleaning the surface of slide foil (A) at regular intervals.

5 Replacing Components



WARNING!

Risk of injury by uncontrolled functions of the applicator.

- ⇒ Disconnect the printer power supply.
- ⇒ Close the compressed air supply before the work.

5.1 Remove the Covers



NOTICE!

Dismantle the cover to arrive the components installed on the carrier plate.

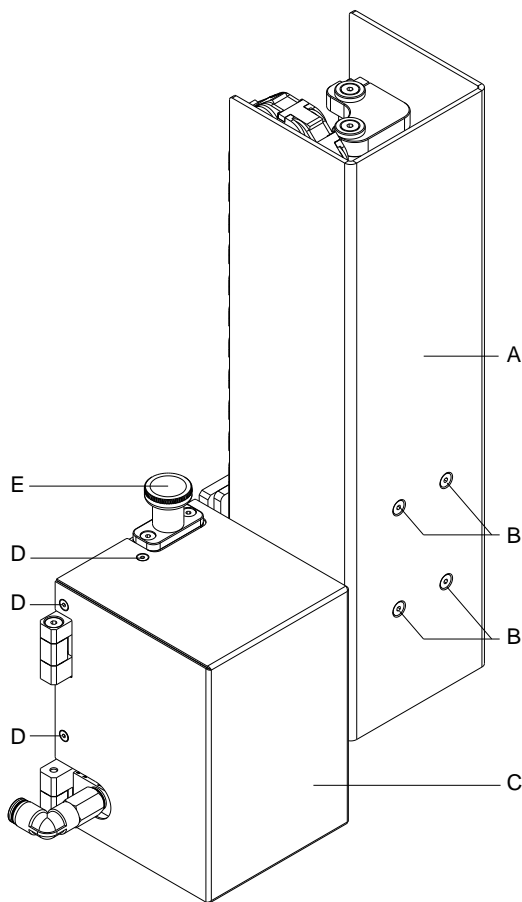

Remove cylinder cover

1. Loosen screws (B).
2. Remove cover (A).

Remove electronics cover

1. Loosen screws (D).
2. Remove cover (C).

Figure 9



NOTICE!

Before starting the normal operation mount the covers again.

5.2 Stick the Slide Foil onto the Pad

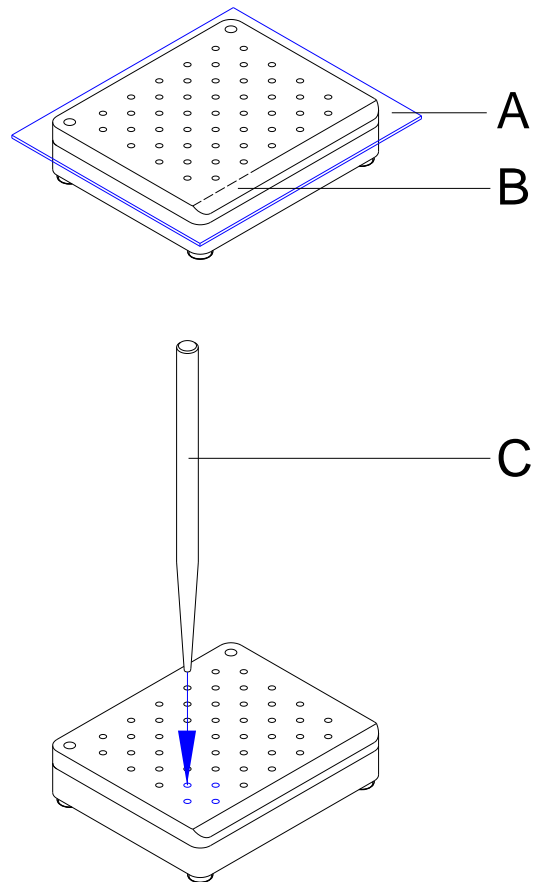

Figure 10

1. Dismount the pad unit (B).
2. Remove the slide foil (A) completely.
3. Clear the surface from remains of glue.
4. Remove the covering foil from the slide foil (A).
5. Put the slide foil (A) with its adhesive side onto the pad (B). Press the slide foil firmly on the pad.
6. Cut off the overlapping parts of the slide foil (A) according to the broken line of the pad (B).
7. Punch the slide foil (A) on the pad (B) using the punch pin (C) appropriate to the whole pattern on the wearing slide foil.
8. Punch the hole completely by turning the pin.
9. Mount the pad unit (B).

5.3 Replace the Valves



WARNING!

Risk of injury by uncontrolled functions of the applicator.

- ⇒ Disconnect the printer power supply.
- ⇒ Close the compressed air supply before the work.

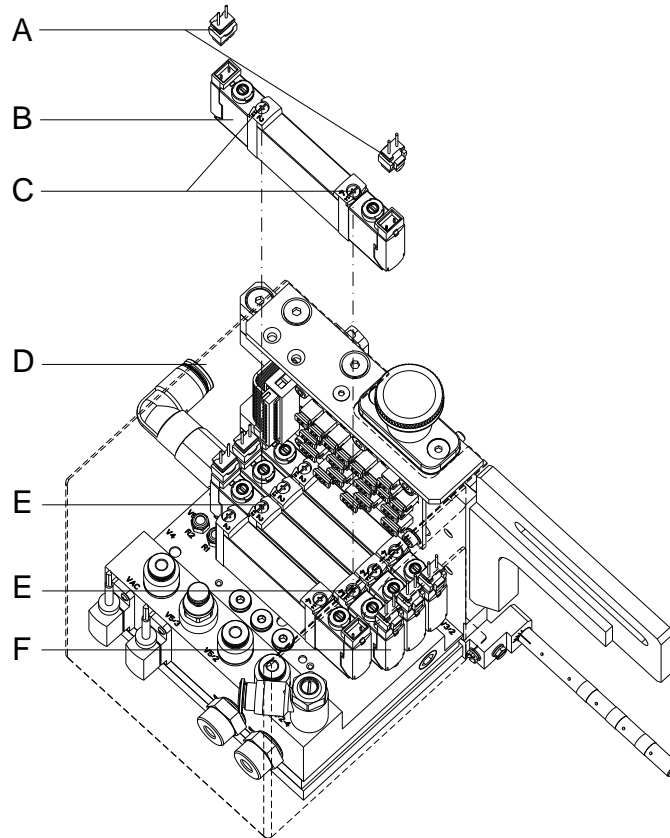

Figure 11

1. Remove the electronics cover (D) as described in chapter 5.1).
2. Remove the connecting line (A).
3. Loosen the screws (E) and remove the valve (F).
4. Install the new valve (B) and take care of the correct position of the provided rubber joint.
5. Mount the valve (B) with the screws (C).
6. Insert the connecting line (A) into the valve.
7. Install the electronics cover (D).

5.4 Replace the PCB



WARNING!

Risk of injury by uncontrolled functions of the applicator.

- ⇒ Disconnect the printer power supply.
- ⇒ Close the compressed air supply before the work.

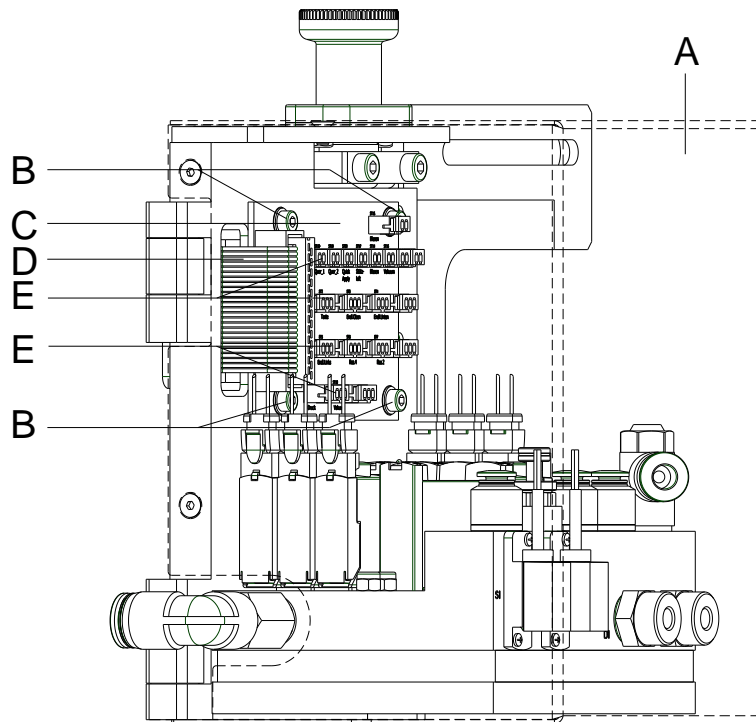

Figure 12

1. Remove the electronics cover (A) as described in chapter 5.1).
2. Remove the connector (E) of valves from the electronics.
3. Remove the cable (D) from the PCB (C).
4. Loosen the screws (B).
5. Remove the PCB (C).
6. Install the new PCB (C) and fix it with the screws (B).
7. Connect the cable (D) with the PCB (C).
8. Connect the plug connector (E) with the PCB (C). Take care of the cable marking.
9. Install again the electronics cover (A).



NOTICE!

Do not forget the connecting position for the re-installation!

5.5 Replace the Cylinder



WARNING!

Risk of injury by uncontrolled functions of the applicator.

- ⇒ Disconnect the printer power supply.
- ⇒ Close the compressed air supply before the work.

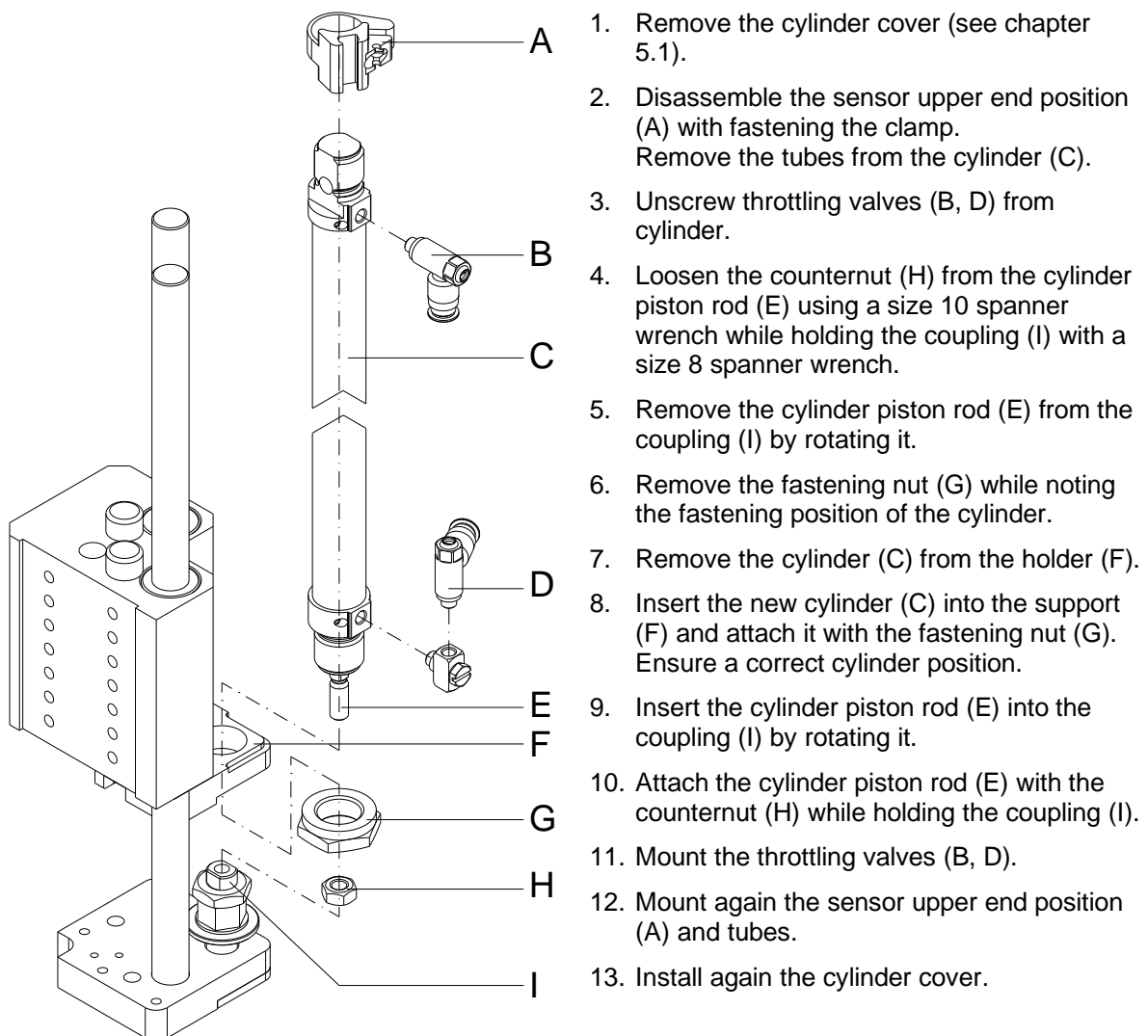

Figure 13



NOTICE!

After replacing a cylinder the sensor positions are to be adjusted (see chapter 5.6).

5.6 Replace the Sensors at the Cylinder



WARNING!

Risk of injury by uncontrolled functions of the applicator.

- ⇒ Disconnect the printer power supply.
- ⇒ Close the compressed air supply before the work.

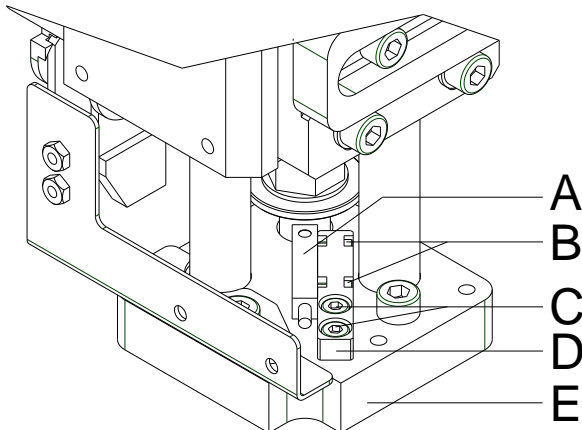

Figure 14

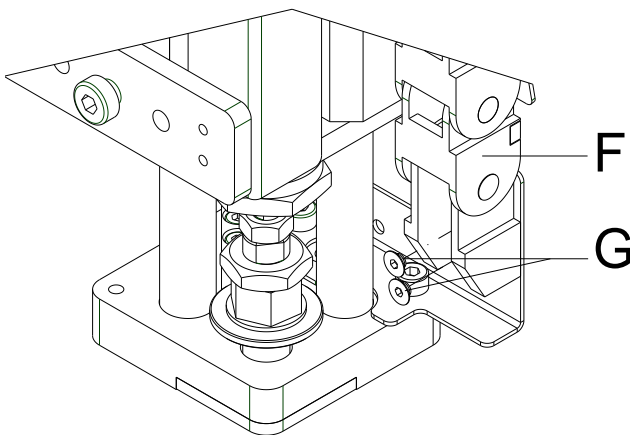

Figure 15

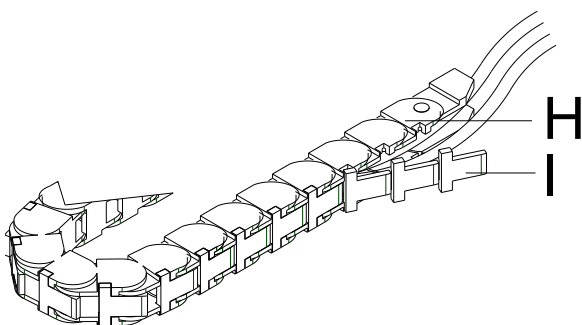

Figure 16

Replace the sensor labelling position (A)

1. Remove the cylinder cover and the electronics cover (see chapter 5.1).
2. Loosen the screws (C).
3. Remove the sensor holder (D) with the sensor (A).
4. Remove the screws (B).
5. Remove the screws (G) in order to loosen the energy track (F) on one side.
6. Detach the T-shaped parts (I) hooked together from the U-shaped parts (H) of the energy track (see Figure 17).
7. Pull out the sensor (A) from the energy track (F).
8. Remove the plug (L) of the sensor (A) from PCB (K).
9. Connect the new sensor (A) with the PCB (K).
10. Insert the new sensor (A) in the energy track (F).
11. Close again the energy track (F). In order to do so, press the T-shaped parts (I) into the U-shaped parts (H).
12. Mount again the energy track (F) and tighten the screws (G).
13. Mount the sensor (A) with screws (B) at the sensor holder (F).
14. Install the sensor holder (D) with the screws (C) at the guiding plate (E).

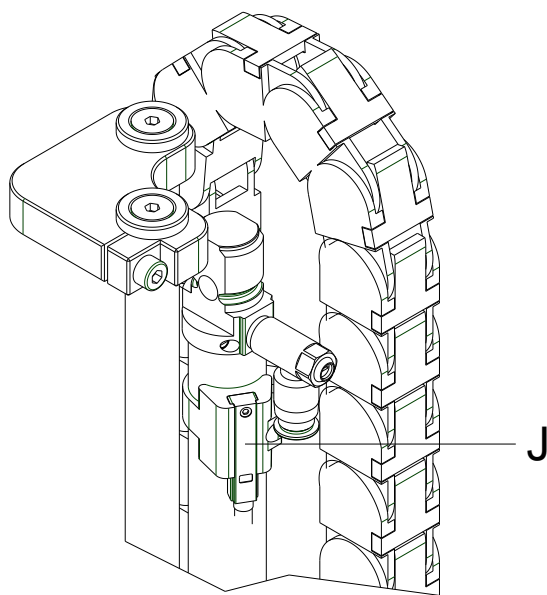

Figure 17

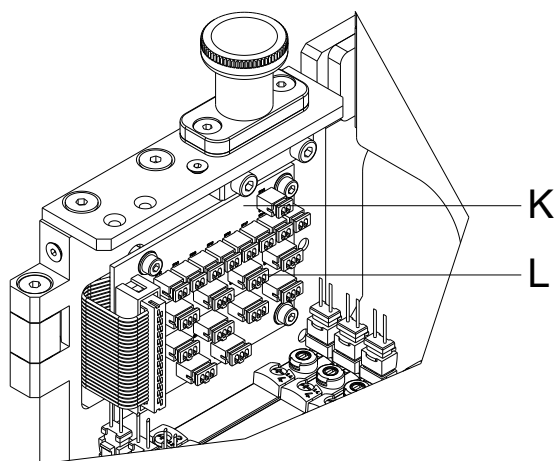

Figure 18

Replace the sensor start position (J)

1. Remove the cylinder cover and the electronics cover (see chapter 5.1).
2. Remove the sensor plug (J) from the PCB (K).
3. After loosening the small thread pin, remove the start position sensor (J) from the support and replace it.
4. Connect the plug of the new sensor (J) with PCB (K).

**NOTICE!**

After replacing a sensor its new position is to be adjusted (see chapter 7.1, page 31).

6 Refit the Options



WARNING!

Risk of injury by uncontrolled functions of the applicator.

- ⇒ Disconnect the printer power supply.
- ⇒ Close the compressed air supply before the work.

6.1 'Quick Apply'

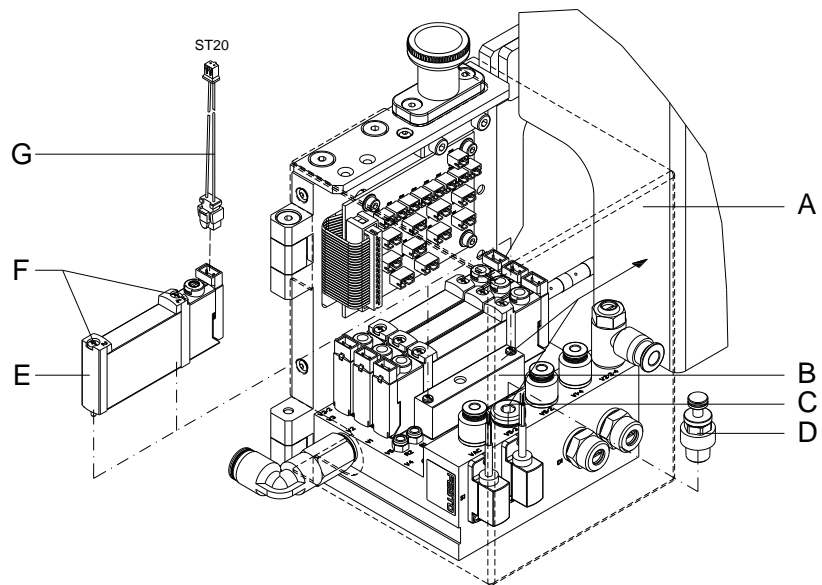

Figure 19

1. Remove the electronics cover (A, see chapter 5.1).
2. Unscrew the cover plate (B).
3. Fix the option 'Quick Apply' valve (E) with the screws (F) at the valve block ensuring the correct position of the supplied rubber seal.
4. Insert the connecting line (G) into the valve (E) and connect it with the slot ST20 on the PCB.
5. Unscrew the blind bolt (C).
6. Mount the throttle silencer (D).
7. Mount again the electronics cover (A).

6.2 Shock Absorber

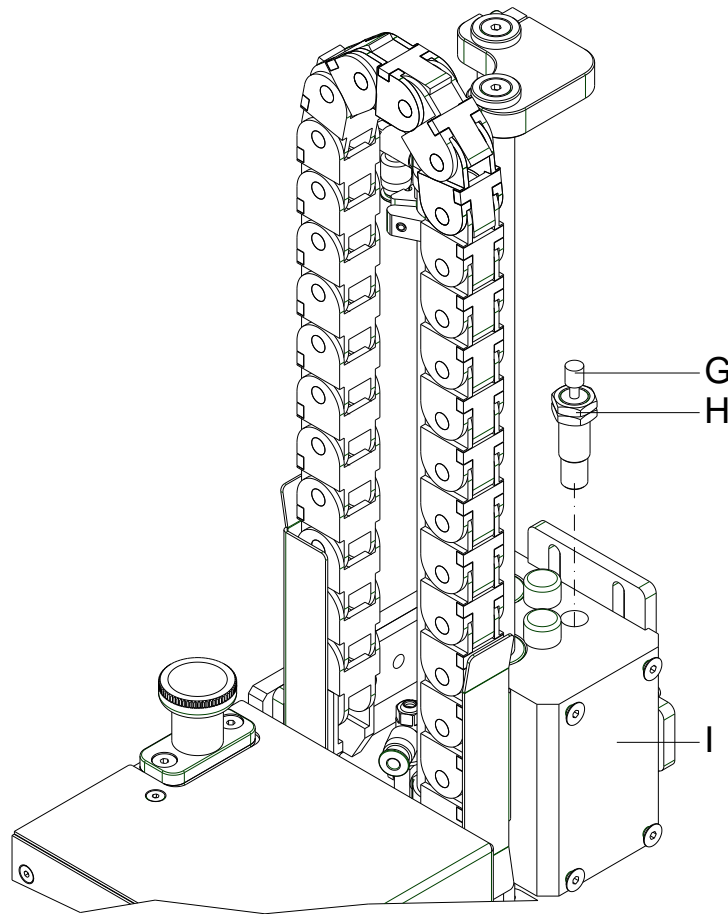

Figure 20

1. Remove the cylinder cover (see chapter 5.1).
2. Screw the shock absorber (G) into the cabinet (I).
3. Secure the position of the shock absorber (G) with the counternut (H).
4. Mount again the cylinder cover.

7 Troubleshooting

7.1 Sensor Labelling Position / Sensor Start Position

The sensor labelling position shows the activation by a LED integrated in the sensor. This LED glows in case of activation.

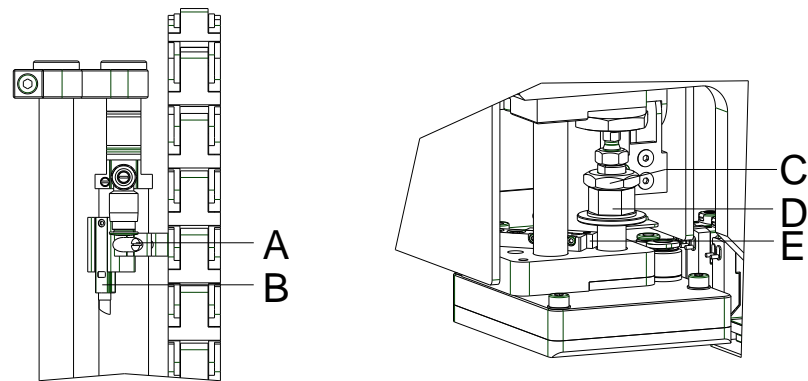

Figure 21

Adjust the sensor start position (B)

1. Loosen the locking ring by loosen the screw (A).
2. Open the compressed air supply.
3. Switch on the printing system and the cylinder is moved to the maximum position (upper end position).
4. Move the locking ring with the sensor (B) so that the LED at the sensor glows.
5. Fix the sensor position by tightening the screw (A) of the locking ring.

Adjust the sensor labelling position (E)

The distance between the sensor (E) and the cam disc (D) should be at least 2 mm. The printing time of the pad may be adjusted by changing the distance.

1. Detach the cam disc (D) and the counternut (C) from each other.
2. Set the distance between the cam disc (D) and the sensor top edge.
3. Secure the position of the cam disc (D) with the counternut (C).

7.2 Supporting Air Throttle Pressure Measuring



NOTICE!

Use a manometer with a measuring scale to 5 bar for measuring the pressure.

**Measuring point 1:
Supporting air
(reference value 1.5
bar)**

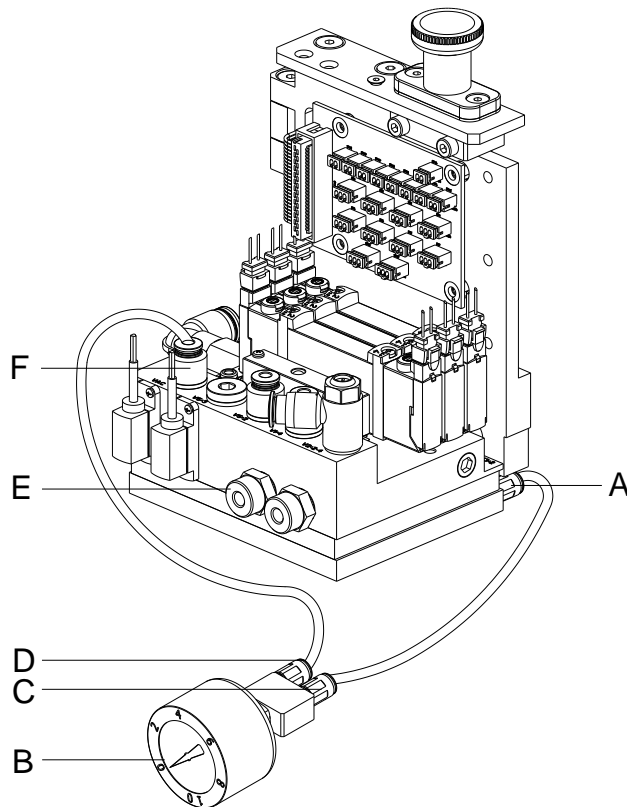

Figure 22

1. Remove the electronics cover (see chapter 5.1).
2. Unscrew the support air holder and then screw a straight push-in fitting (A) in the support air channel.
3. Connect the measuring instrument with hoses to the push-in fittings (A-C and D-F).
4. Switch on the pressure 'supporting air'.
5. If needed, set the pressure at the throttling valve (E).
6. After measurement and setting, unscrew the push-in fitting (A) and then screw again the support air holder.
7. Mount again the electronics cover.



CAUTION!

Malfunction at label takeover from dispensing edge to pad.
Not enough vacuum / support air.

⇒ After the pressure measuring, reconnect all connectors and check the interference fit of the tubes.

7.3 Vacuum Throttle Pressure Measuring



NOTICE!

Use a manometer with a measuring scale to 1 bar for measuring the pressure.

**Measuring point 2:
Vacuum (reference
value -0.4 bar)**

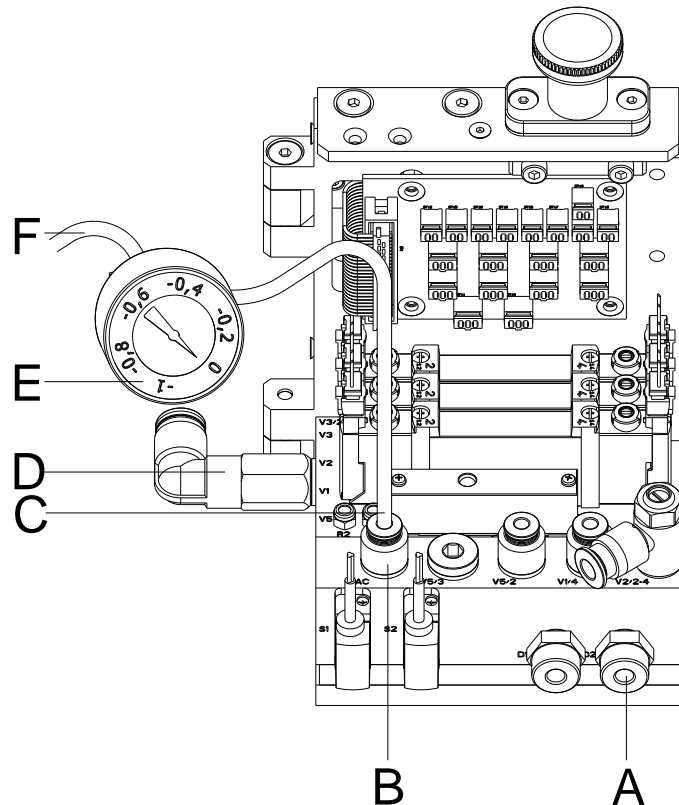

Figure 23

1. Remove the electronics cover (see chapter 5.1).
2. Insert the vacuum hose (C) from the vacuum measuring instrument (E) into the push-in fitting (B).
3. Switch on the pressure 'vacuum'.
4. Sealing the point (F) of the vacuum measuring device (E).
5. Measure the vacuum value.
6. If needed, set the pressure at the throttling valve (A).
7. Mount again the electronics cover.



CAUTION!

Malfunction during the label transfer from the dispensing edge to the pad. Vacuum/supporting air too low.

⇒ Following the pressure measurement, re-establish the connections and check the tubes for tightness.

7.4 Pressure Control/Vacuum Control Adjustment



Setting switching vacuum control



Press the key **F** to access the function menu.



Press the key  until the menu *Label applicator* is displayed.

Press the key  to select the menu.

Press the key  until the inputs and outputs are displayed.

With the keys  and  the appropriate output for setting and/or resetting of output signals can be selected.

With the keys  and  the appropriate output can be set and/or reset.

Press the key  to change to output O₇ and switch on the vacuum valve with key  (1 = On).

Place the label which is to be printed below the pad so that all suction holes are covered by the label. By the applied vacuum the label remains under the pad.

In case of a correct operation, the input value I₅ should represent the value 1 (see display). Otherwise the switching threshold of vacuum sensor must be set with the right rotary potentiometer (B, see Figure 24) in that way that the switching threshold changed the value from 0 to 1. Turn the rotary potentiometer (B, Figure 24) clockwise and/or counterclockwise.

Remove the label from the pad. The input value I₅ should indicate the value 0. If a label is sucked again to the pad, the value should change to 1.

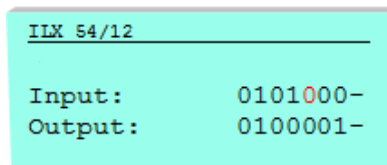

Switching limit vacuum sensor
Input I₅ = 0

Vacuum is switched On
(Output O₇ = 1)

The system recognizes that no label is under the pad

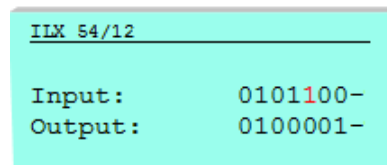

Switching limit vacuum sensor
Input I₅ = 1

Vacuum is switched On
(Output O₇ = 1)

The system recognizes that a label is under the pad



Set the switching pressure control



Press the key **F** to access the function menu.

Press the key  until the menu *Label applicator* is displayed.

Press the key  to select the menu.

Press the key  until the inputs and outputs are displayed.

With the keys  and  the appropriate output for setting and/or resetting of output signals can be selected.

With the keys  and  the appropriate output can be set and/or reset.

The air pressure is set to a minimum pressure of 2.5 bar. The input value I_4 should now represent the value 1 (see display). Otherwise the switching threshold of pressure sensor must be set with the left rotary (A, Figure 24) in that way that the switching threshold changed the value from 0 to 1. Turn the rotary potentiometer (A, Figure 24) clockwise and/or counterclockwise.

The air pressure is set to < 2.5 bar. The input value I_4 should now represent the value 0. If the air pressure is set to > 2.5 bar, the value should again change to 1.

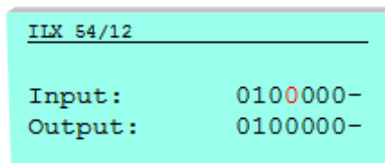

Switching limit pressure sensor
Input $I_4 = 0$

The system recognizes that the minimum pressure of 2.5 bar is not set

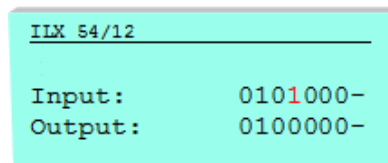

Switching limit pressure sensor
Input $I_4 = 1$

The system recognizes that the working pressure is $\geq 2,5$ bar

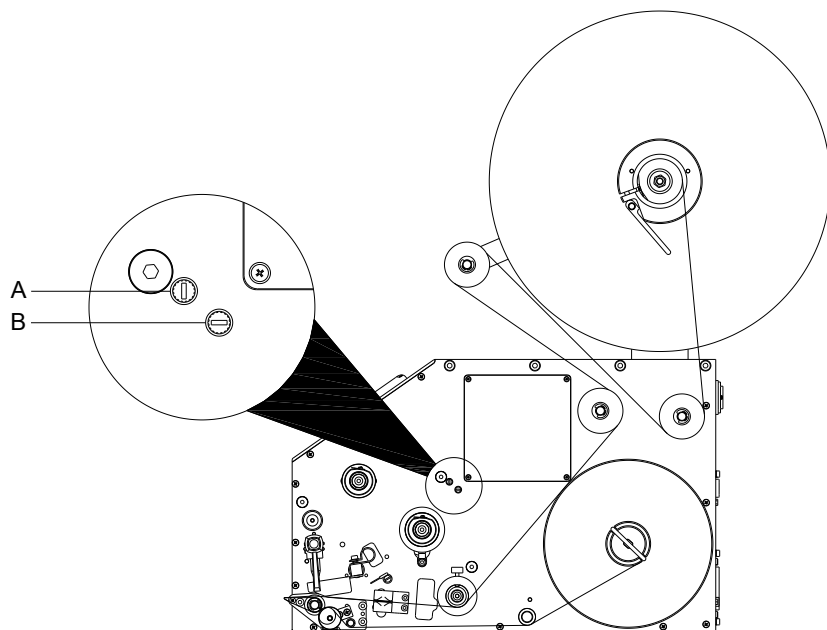

Figure 24

7.5 Error Indications

Error	Cause	Solution
Insufficient vacuum on pad	In cyclical operation the control valve 'vacuum' is not controlled. Defective applicator PCB.	Change the applicator PCB.
	No pressure at the output of throttle valve 'vacuum' or the pressure cannot be adjusted.	Adjust and/or change the throttle valve.
	No vacuum at the output of vacuum generator.	Change the sound absorber if it is soiled. Change the vacuum generator if it is defect.
	Leaking vacuum chain.	Measuring as described in chapter 7.2, page 32. Check the transmission elements and replace them if necessary.
	Insufficient vacuum at the pad. Suction channels at the pad or slide foil clotted.	Clean the suction channels and/or change the slide foil.
Fault in the cylinder movement	The condition of valve control is not indicated with the LED at the valve connector.	Check the connections.
	Defective applicator PCB.	Change the applicator PCB.
	No pressure at the output of miniature pressure regulator or the pressure cannot be adjusted.	Adjust and/or change the miniature pressure regulator.
	No pressure at the output of one of the throttle valves at the cylinder or the pressure cannot be adjusted.	Adjust and/or change the throttle valve.

Error	Cause	Solution
Loss of blow air	The valve is not activated. The LED at valve does not glow. Defective applicator PCB.	Change applicator PCB.
	Insufficient pressure at pad with an activated valve. Defective pneumatic tubes.	Replace pneumatic tubes.
Loss of applicator function	Compressed air failure.	Check the connections.
	Defective applicator PCB.	Change the applicator PCB.
Loss of support air	Valve is not controlled. Defective applicator PCB.	Change the applicator PCB.
	Insufficient pressure at blow tube with an activated valve. Defective pneumatic tubes.	Change the pneumatic tubes.
	Defective or wrong adjusted throttle valve.	Adjust and/or change the throttle valve.
Permanent error at the label transfer via pad	Faulty pad position in the transfer position to the peel off edge of the printer.	Correct the position (backward edge of the pad approx. 1 mm above the peel off edge of the printer).
	Insufficient or missing vacuum.	Adjust the vacuum at the throttle valve.
	Support air does not blow exactly the label to the pad.	Adjust the blow tube. Adjust the pressure of the support air via throttle valve 'support air'. Adjust the switch on delay.

8 Wiring Plan

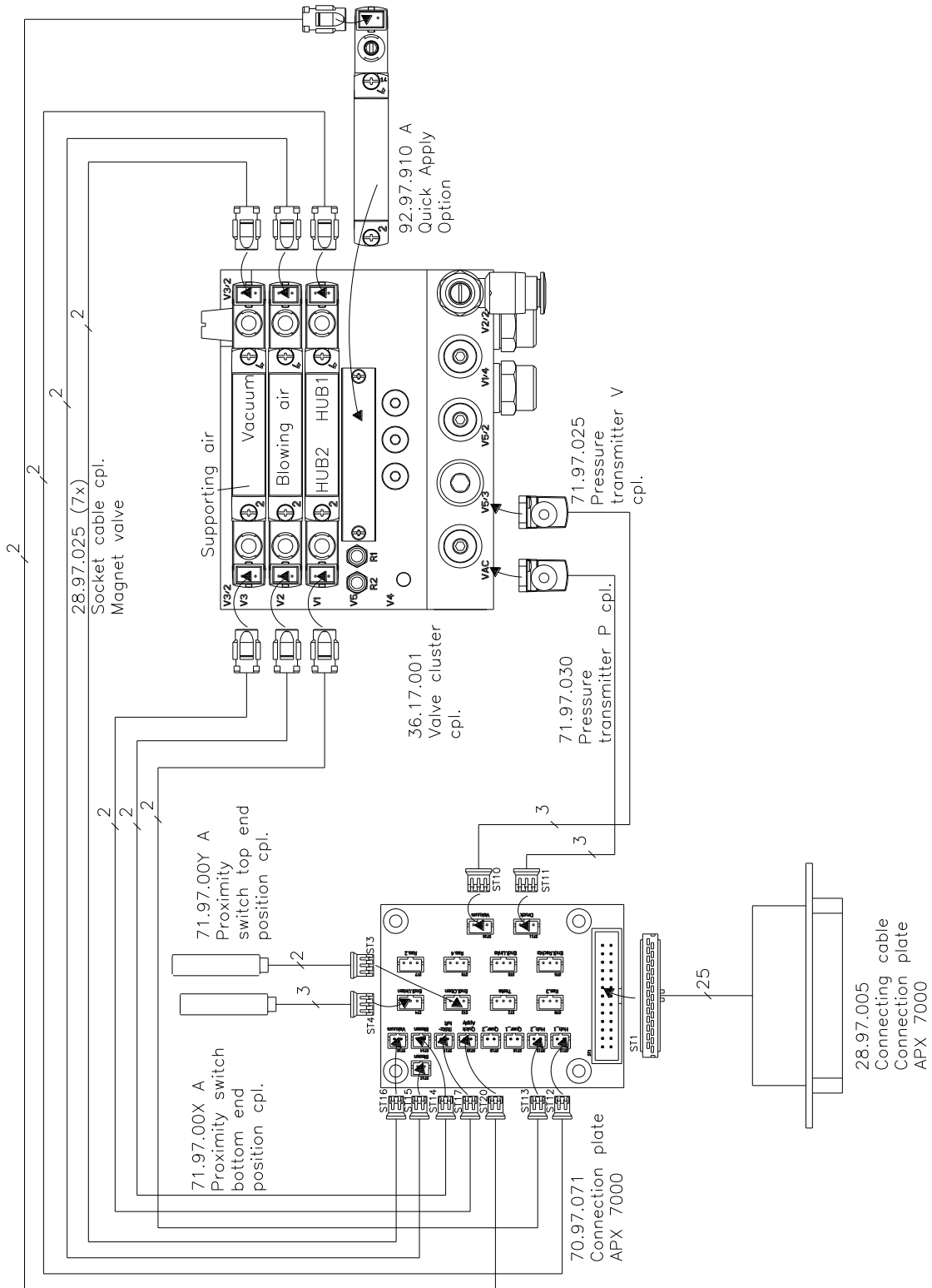

Figure 25

9 Pneumatic Plan

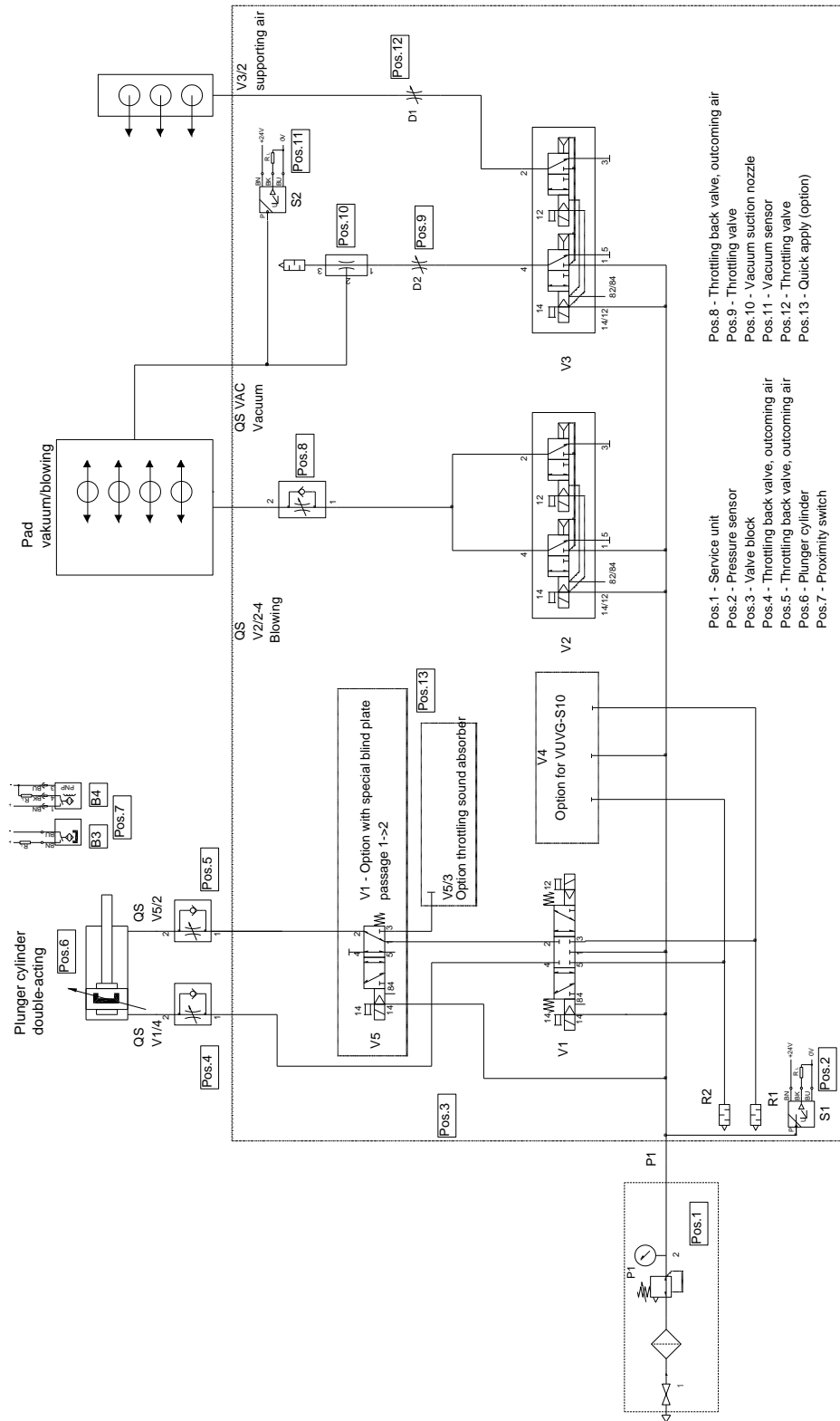

Figure 26

10 Connector Pin Assignment of PCB

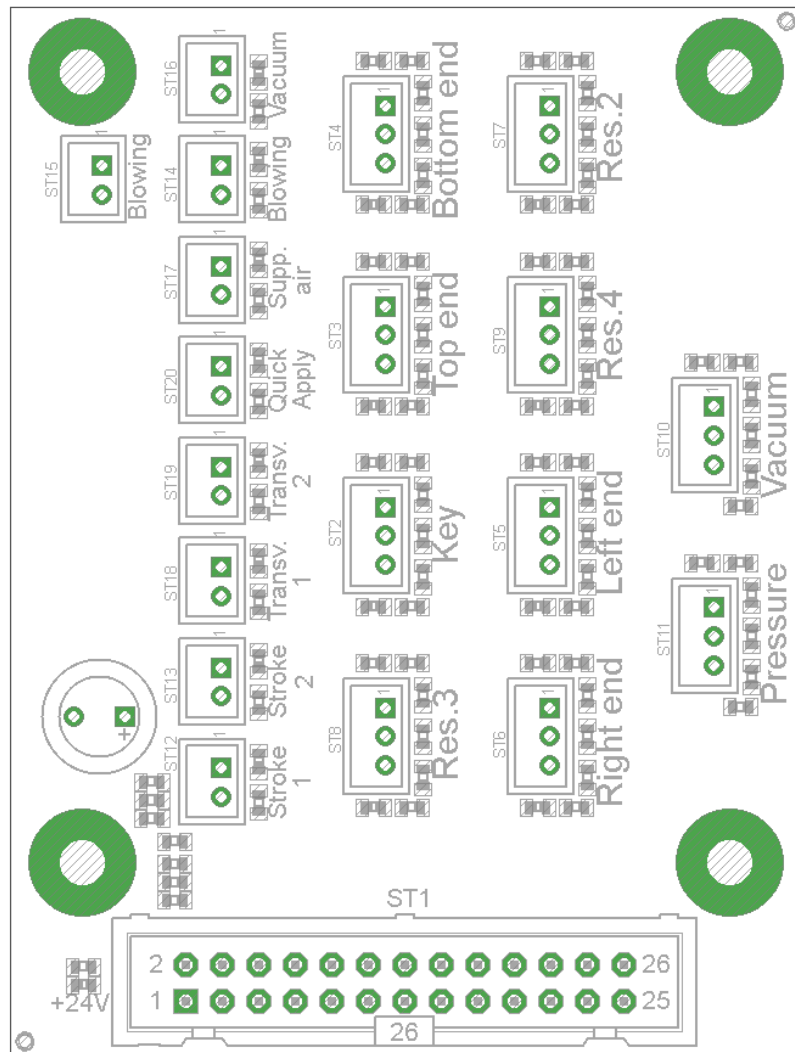
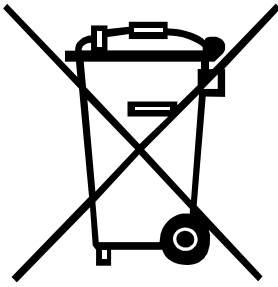

Figure 27

11 Environmentally-Friendly Disposal



Manufacturers of B2B equipment are obliged to take back and dispose of old equipment that was manufactured after 13 August 2005. As a principle, this old equipment may not be delivered to communal collecting points. It may only be organised, used and disposed of by the manufacturer. Valentin products accordingly labelled can therefore be returned to Carl Valentin GmbH.

This way, you can be sure your old equipment will be disposed of correctly.

Carl Valentin GmbH thereby fulfils all obligations regarding timely disposal of old equipment and facilitates the smooth reselling of these products. Please understand that we can only take back equipment that is sent free of carriage charges.

The electronics board of the printing system is equipped with a battery. This must only be discarded in battery collection containers or by public waste management authorities.

Further information on the WEEE directive is available on our website www.carl-valentin.de.

12 Index

C	
cleaning.....	20
connector pin assignment, PCB.....	43
cylinder cover, remove.....	21
cylinder, replacing.....	25
D	
document notes.....	5
E	
electronics cover, remove.....	21
environmentally-friendly disposal.....	45
I	
instructions.....	5
O	
overview, applicator.....	11, 12, 13
P	
pad, sticking slide foil.....	22
PCB, replacing.....	24
pneumatic	
blow tube.....	15
control valves.....	16, 17
cylinder.....	15
maintenance unit.....	15
pad.....	15
vacuum generator.....	15
valve block.....	15
pneumatic plan.....	41
pressure measuring	
supporting air throttle.....	32
vacuum throttle.....	33
Q	
quick apply, refitting.....	29
R	
refit options	
quick apply.....	29
shock absorber.....	30
S	
safety instructions.....	8
clothing.....	7
protective clothing.....	7
protective equipment.....	8
workplace.....	7
safety marking.....	9

sensor	
labelling position	14
pressure.....	14
replacing	26, 27
start position	14
troubleshooting	31
vacuum	14
shock absorber, refitting.....	30
T	
tools	19
troubleshooting	
error indication	36, 37
pressure control	35
pressure measuring	32, 33
sensor start position	31
vacuum control.....	34
U	
user notes	5
V	
valves, replacing.....	23
W	
wiring plan	39



Carl Valentin GmbH
Neckarstraße 78 – 86 u. 94 . 78056 Villingen-Schwenningen
Phone +49 7720 9712-0 . Fax +49 7720 9712-9901
info@carl-valentin.de . www.carl-valentin.de