

# **PNEUMATIC APPLICATOR FOR COMPA III / COMPA V C220 / C300 / C400**

Operating Manual



Copyright by Carl Valentin GmbH / 7942505.1023

Information on the scope of delivery, appearance, performance, dimensions, and weight reflect our knowledge at the time of printing.

We reserve the rights to make modifications.

All rights, including those regarding the translation, are reserved.

No part of this document may be reproduced in any form (print, photocopy, or any other method) or edited, copied, or distributed electronically without written permission from Carl Valentin GmbH.

Due to the constant further development of our devices discrepancies between manual and device can occur.

Please check [www.carl-valentin.de](http://www.carl-valentin.de) for the latest update.

### **Trademarks**

All named brands or trademarks are registered brands or registered trademarks of their respective owners and may not be separately labelled. It must not be concluded from the missing labelling that it is not a registered brand or a registered trademark.

The pneumatic applicator complies with the following safety guidelines:

**CE** Electromagnetic Compatibility Directive (2014/30/EU)  
EG Machinery Directive (2006/42/EG)



### **Carl Valentin GmbH**

Postfach 3744  
78026 Villingen-Schwenningen  
Neckarstraße 78 – 86 u. 94  
78056 Villingen-Schwenningen

Phone +49 7720 9712-0  
Fax +49 7720 9712-9901

E-Mail [info@carl-valentin.de](mailto:info@carl-valentin.de)  
Internet [www.carl-valentin.de](http://www.carl-valentin.de)

## Table of Contents

<b>1</b>	<b>Introduction.....</b>	<b>5</b>
1.1	General Instructions .....	5
1.2	Intended Use .....	6
<b>2</b>	<b>Safety Instructions .....</b>	<b>7</b>
2.1	Safety Labels.....	8
2.2	Operating Conditions.....	9
<b>3</b>	<b>Product Description .....</b>	<b>11</b>
3.1	Important Characteristics .....	12
3.2	Technical Data.....	12
3.3	Device Overview.....	13
3.4	Pads .....	15
<b>4</b>	<b>Installation.....</b>	<b>17</b>
4.1	Scope of Delivery .....	17
4.2	Mount the Applicator to the Printer.....	18
4.3	Pierce the Universal Tamp Pad.....	19
4.4	Prepare for Using a Spring-Mounted Tamp Pad .....	20
4.5	Mount the Pad .....	21
4.6	Mount the Stopper .....	22
4.7	Connections.....	23
<b>5</b>	<b>Configuration .....</b>	<b>25</b>
5.1	Configuration Parameter .....	25
5.2	Settings in Printer Function Menu .....	26
<b>6</b>	<b>Signal Diagrams .....</b>	<b>31</b>
6.1	Print - Apply .....	31
6.2	Apply - Print .....	31
<b>7</b>	<b>Mechanical Adjustments .....</b>	<b>33</b>
7.1	Align the Pad .....	33
7.2	Adjust the Parallelism between Pad and Dispensing Edge ..	34
7.3	Open the Holes on the Blow Tube .....	35
7.4	Align the Blow Tube .....	36
7.5	Adjust the Stopper .....	37
<b>8</b>	<b>Pneumatic Adjustments .....</b>	<b>39</b>
8.1	Control Valves .....	39
8.2	Adjust the Pad Movement Speed.....	41
8.3	Adjust Vacuum and Supporting Air .....	42
<b>9</b>	<b>Operation.....</b>	<b>43</b>
9.1	Load the Label Material.....	43
9.2	Set the Dispenser Mode .....	44
9.3	Initial Operation .....	45
<b>10</b>	<b>Error Messages.....</b>	<b>47</b>
10.1	Error Messages of the Printer .....	47
10.2	Error Messages of the Applicator .....	47
<b>11</b>	<b>Environmentally-Friendly Disposal .....</b>	<b>49</b>
<b>12</b>	<b>Index .....</b>	<b>51</b>



# 1 Introduction

## 1.1 General Instructions

Essential information and instructions in this document are designated as follows:



**DANGER** identifies an extraordinarily great and immediate danger which could lead to serious injury or even death.



**WARNING** identifies a possible danger could lead to serious bodily injury or even death if sufficient precautions are not taken.



**WARNING** of cutting injuries.  
Pay attention that cutting injuries caused by blades, cutting devices or sharp-edged parts are avoided.



**WARNING** of hand injuries.  
Pay attention that hand injuries caused by closing mechanical parts of a machine/equipment are avoided.



**WARNING** of hot surfaces.  
Pay attention so as not to come into contact with hot surfaces.



**CAUTION** indicates a potentially dangerous situation which could lead to moderate or light bodily injury or damage to property.



**NOTICE** gives you tips. They make a working sequence easier or draw attention to important working processes.



Gives you tips on protecting the environment.



Handling instruction



Optional accessories, special fittings

Datum

Information in the display

## 1.2 Intended Use

The device is a state-of-the-art device which complies with the recognized safety-related rules and regulations. Despite this, a danger to life and limb of the user or third parties could arise and the device or other property could be damaged while operating the device.

The device may only be used while in proper working order and for the intended purpose. Users must be safe, aware of potential dangers and must comply with the operating instructions. Faults, those which affect safety, must be remedied immediately.

The pneumatic applicators C220, C300 and C400 are optional devices to use with label printers of the Compa III/Compa V series for automatically applying the printed label onto the product. Any other or additional use is not intended. The manufacturer/supplier is not liable for damage resulting from misuse. Any misuse is at your own risk.

Intended use includes heeding the operating manual, including the maintenance recommendations/regulations specified by the manufacturer.

## 2 Safety Instructions

- Before mounting the delivered components disconnect the printer from the power supply and close the shutoff valve at the applicator.
- Only connect the device to other devices which have a protective low voltage.
- Switch off all affected devices (computer, printer, accessories) before connecting or disconnecting.
- In operation, moving parts are easily accessible. This applies especially for the zone, where the pad is moved between the starting and the labelling position. During operation do not reach into that zone and keep long hair, loose clothes, and jewellery distant.  
Before any manipulations in those areas, close the shutoff valve.
- The device may only be used in a dry environment, do not expose it to moisture (sprays of water, mists, etc.).
- Do not use the device in an explosive atmosphere.
- Do not use the device close to high-voltage power lines.
- Operate the direct print module only in an environment protected against abrasive dust, swarf, and other similar impurity.



### NOTICE!

With the open printing unit (due to construction) the requirements of EN 62368-1 regarding fire protection casing are not fulfilled. These must be ensured by the installation into the end device.

- Maintenance and servicing work can only be conducted by trained personnel.
- Operating personnel must be trained by the operator based on the operating manual.
- Conduct only the actions described in these operating instructions. Any work beyond this may only be performed by the manufacturer or upon agreement with the manufacturer.
- Unauthorized interference with electronic modules or their software can cause malfunctions.
- Other unauthorized work on or modifications to the device can also endanger operational safety.
- Always have service work done in a qualified workshop, where the personnel have the technical knowledge and tools required to do the necessary work.
- There are warning stickers on the direct print modules that draw your attention to dangers. Therefore the warning stickers are not to be removed as then you and others cannot be aware of dangers and may be injured.
- When incorporating the unit into the overall system, make sure that safety precautions are taken so that no-one can reach into the working area.
- Before starting the machine, all protective guards must be fitted.

## 2.1 Safety Labels

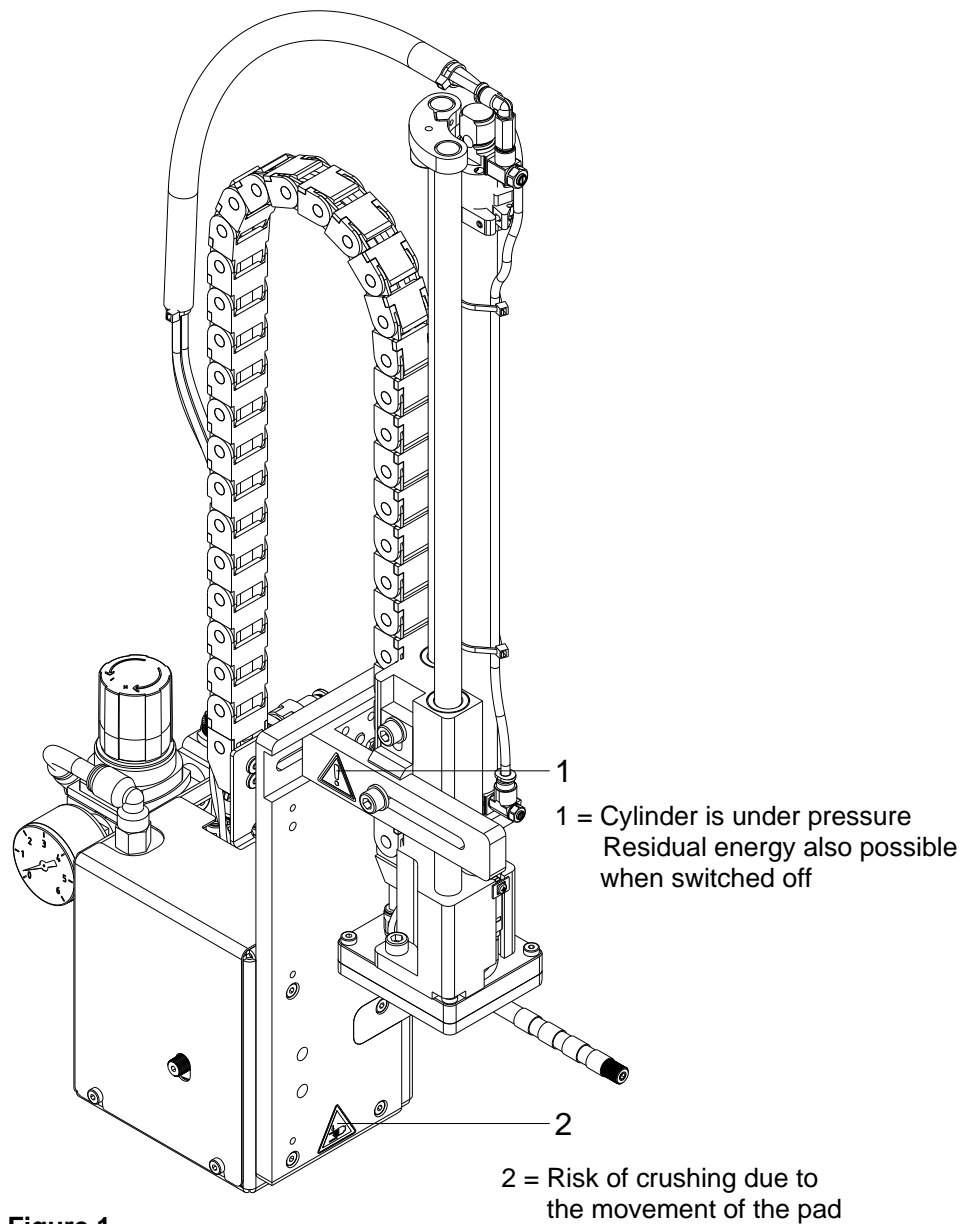

Figure 1



### CAUTION!

There is a risk of injury due to the movement of the pad downwards and back up again.

- ⇒ Do not reach into the working area of the pad.
- ⇒ Keep hair, loose clothing, and items of jewellery out of this area.
- ⇒ When incorporating the unit into the overall system, safety precautions must be taken so that no-one is able to reach into the working area.



## 2.2 Operating Conditions

**Before initial operation and during operation** these operating conditions must be observed to guarantee safe and interference-free service of our printers.

Therefore please carefully read these operating conditions.

Shipment and storage of our printers are **only** allowed in original packing.

Installation and initial operation of printer is only allowed if operating conditions were **fulfilled**.

Commissioning is prohibited until it can be established that, where relevant, the machine into which the partly completed machinery is to be incorporated complies with the provisions of Machinery Directive 2006/42/EC.

Initial operation, programming, operation, cleaning, and service of our printers are only recommended after careful study of our manuals.

Operation of printer is only allowed by especially trained persons.



### NOTICE!

Perform trainings regularly.

These indications are also valid for someone else's equipment supplied by us.

Only use original spare and exchange parts.



### NOTICE!

This is a machine of type A. This machine can cause interferences in residential areas; in this case it can be required from operator to accomplish appropriate measures and be responsible for it.

### Air convection

To avoid inadmissible heating, free air convection must be ensured.

### Limit values

Ambient temperature °C (operation): Min. +5 Max. +35

Ambient temperature °C (storage): Min. -20 Max. +60

Relative air humidity % (operation): Max. 80

Relative air humidity % (storage): Max. 80  
(bedewing of printers not allowed)

**Guarantee**

We do not take any responsibility for damage caused by:

- Ignoring our operating conditions and operating manual.
- Incorrect electric installation of environment.
- Building alterations of our printers.
- Incorrect programming and operation.
- Not performed data protection.
- Using of not original spare parts and accessories.
- Natural wear and tear.

When (re)installing or programming our printers please control the new settings by test running and test printing. Herewith you avoid faulty results, reports, and evaluation.

Only specially trained staff is allowed to operate the printers.

Control the correct handling of our products and repeat training.

We do not guarantee that all features described in this manual exist in all models. Caused by our efforts to continue further development and improvement, technical data might change without notice.

By further developments or regulations of the country illustrations and examples shown in the manual can be different from the delivered model.

Please pay attention to the information about admissible print media and the notes to the printer maintenance, to avoid damages or premature wear.

We endeavoured to write this manual in an understandable form to give and you as much as possible information. If you have any queries or if you discover errors, please inform us to give us the possibility to correct and improve our manual.

### 3 Product Description

The pneumatic applicators C220, C300 and C400 are optional devices to use with label printers of the Compa III/Compa V series for automatically applying the printed label onto the product.

The labels are transferred with a pad, which moves between the two positions, starting position and labelling position, by a compressed-air driven pneumatic cylinder.

- In the starting position, the label is picked up from the printer.
- A sensor at the cylinder signals when the pad is in the starting position.
- The label is removed from the carrier ribbon directly at the dispensing edge of the printer. It is sucked on the pad by a vacuum via drillings at the bottom of the pad.
- For support, the label is also blown against the pad (supporting air) with an air current coming from a blow tube.
- The correct transfer of the label is controlled by a vacuum sensor.
- Next, the pad is moved down into the labelling position. Reaching the labelling position is confirmed by another sensor (labelling position sensor).
- In the labelling position the label is transferred onto the product.
- While the pad is moving back into the starting position, the vacuum sensor checks whether the label has been removed from the pad.

#### Application of the label

The label can be applied with three different methods:

##### **Stamp on**

The label is pressed directly onto the product.

##### **Blow on**

The blow pad is moved to a fixed height at which there is a residual distance of max 10 mm to the product. The label is blown onto the product by an air stream.

##### **Roll on**

In the starting position the label is forwarded until touching the roller of the roll on pad. At the labelling position the roller is pressed onto the product. Then the label is applied and rolled on by the movement of the product.

### 3.1 Important Characteristics

- The supporting air and the vacuum as well as the speed of the cylinder are adjustable. That way the applicator can be adapted to different label materials and sizes.
- The pressure for the cylinder movement is reduced in relation to the operating pressure of the entire labelling machine so that the danger of injury is reduced as much as possible.
- To avoid contamination within the vacuum channels they are cleaned by air pressure impulse at the end of each application.
- For integration into a superordinated process the printers of Compa III/Compa V series can be equipped with *Dispenser I/O*.

### 3.2 Technical Data

	Stamp on	Blow on	Roll on
Label width*	25 ... 176 mm	25 ... 176 mm	25 ... 176 mm
Label height*	25 ... 200 mm	25 ... 100 mm	80 ... 200 mm
C220: Cylinder stroke Cylinder stroke below the device	220 mm 86 mm	220 mm 86 mm	220 mm 86 mm
C300: Cylinder stroke Cylinder stroke below the device	300 mm 166 mm	300 mm 166 mm	300 mm 166 mm
C400: Cylinder stroke Cylinder stroke below the device	400 mm 266 mm	400 mm 266 mm	400 mm 266 mm
Compressed air pressure	4.5 bar	4.5 bar	4.5 bar
Product surface	flat	flat	flat
Product height variable	✓	-	✓
Product height fixed	✓	✓	✓
Product fixed	✓	✓	-
Product linear movement	-	✓	✓
Compressed air control/vacuum control	available		
Service unit	filter regulation with manometer and shut-off valve		
Voltage supply/current supply	by label printer Compa III/Compa V		
Applicator weight	approx. 4.5 kg + pad		

\* depending on the selected printer Compa III/Compa V and the pad

### 3.3 Device Overview

#### Front view

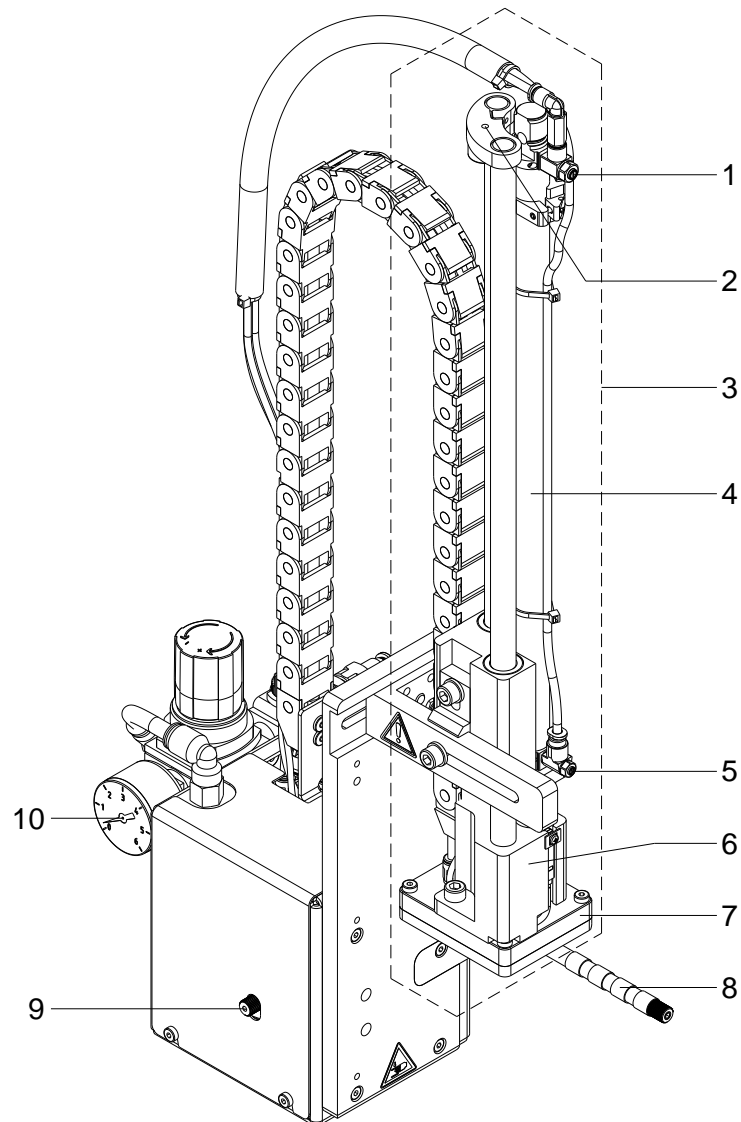

**Figure 2**

- 1 = Upper cylinder throttle valve
- 2 = Stopper for the operation mode 'Blow on'
- 3 = Cylinder unit
- 4 = Pneumatic cylinder
- 5 = Lower cylinder throttle valve
- 6 = Pad holder
- 7 = Pad (application specific)
- 8 = Blow tube for supporting air
- 9 = Knurled screw for attaching the applicator to the printer
- 10 = Main pressure manometer

## Rear view

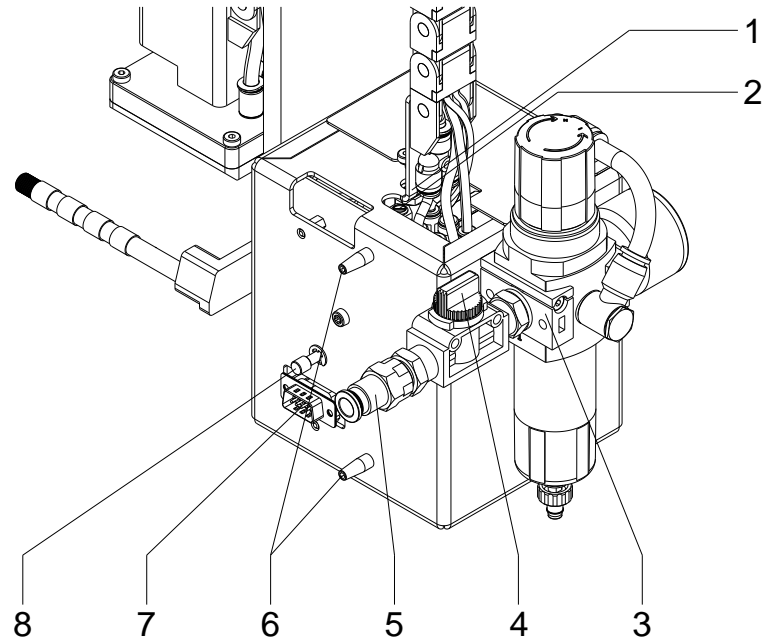
**Figure 3**

- 1 = Supporting air throttle valve
- 2 = Vacuum throttle valve
- 3 = Service unit
- 4 = Shutoff valve
- 5 = Compressed air connector
- 6 = Pins
- 7 = Interface to the printer
- 8 = Knurled screw for attaching the applicator to the printer

### 3.4 Pads

#### Tamp pad

Universal tamp pad

Standard sizes:  
70 x 60 mm and 90 x 90 mm

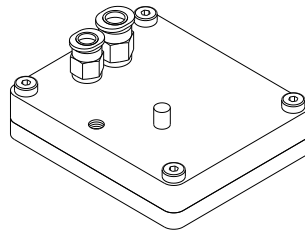

**Figure 4**

Universal tamp pad

Standard sizes:  
116 x 102 mm and 116 x 152 mm

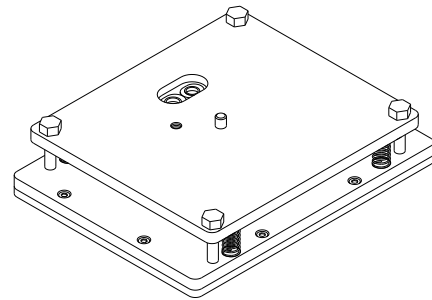
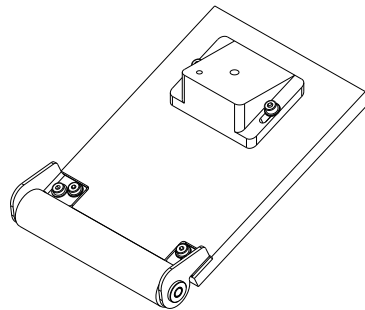

**Figure 5**

Universal tamp are available in different standard sizes. According to the size of the label the holes may be pierced by the customer. For that purpose a piercing pin is included in the delivery contents.

On request, tamp pads customized to the label sized are delivered.

#### Roll-on pads



**Figure 6**

Roll-on pads are only produced on request customized to the label size.

#### Blow pads

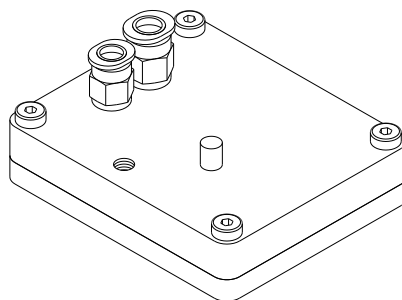

**Figure 7**

Blow pads are only produced on request customized to the label size.





## 4 Installation

### 4.1 Scope of Delivery



#### NOTICE!

Please keep the original packaging in case the applicator must be returned.

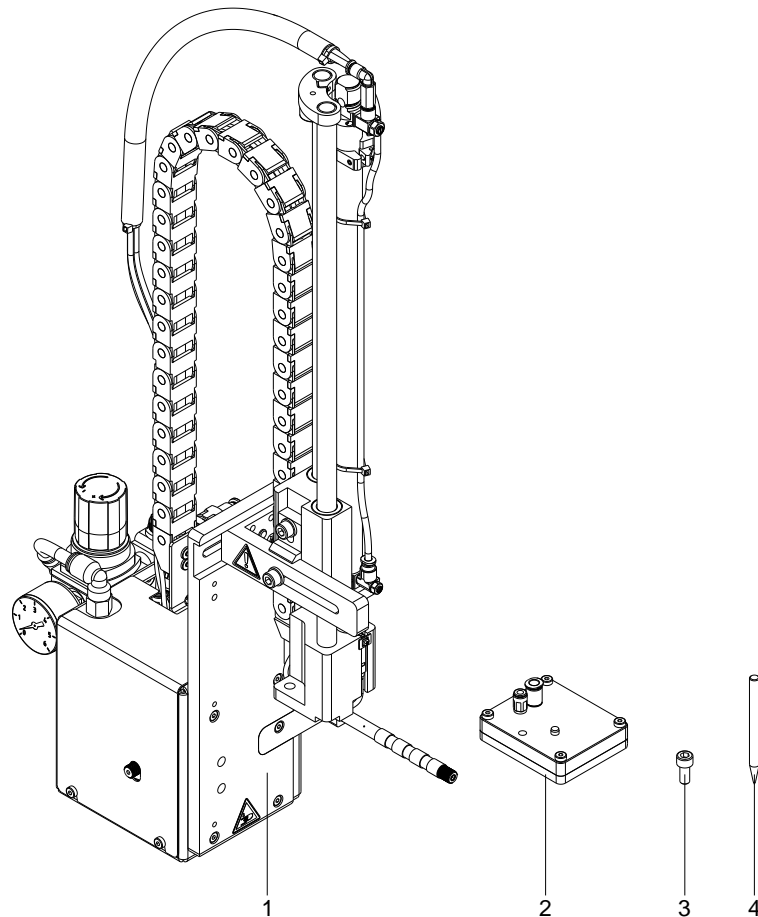

**Figure 8**

- 1 = Applicator with cylinder
- 2 = Pad (according to command)
- 3 = Cylinder screw (part of the pad)
- 4 = Piercing pin (at universal tamp pads only)



#### CAUTION!

The label printer and the applicator can be damaged by moisture and water.

⇒ Set up the label printer with applicator only in dry locations protected from splash water.

## 4.2 Mount the Applicator to the Printer



### CAUTION!

Danger of injury by inadvertent move out of the cylinder.

- ⇒ Disconnect the printer from the power supply before mounting the applicator.
- ⇒ Connect the compressed air only after mounting the applicator to the printer.

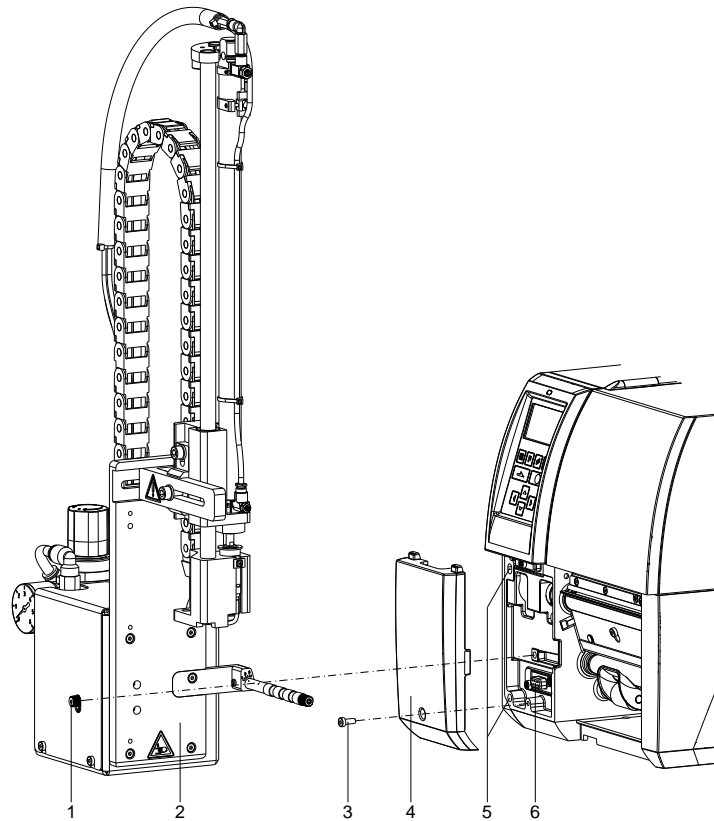

**Figure 9**

1. Unscrew the screw (3) and remove the front panel bottom left (4).
2. Insert the pneumatic applicator (2) with the rear pins (6, Figure 3) into the holes (5) of the printer.
3. Press the applicator against the printer. That way the plug of the applicator will be connected to the peripheral port (6) of the printer.
4. Fix the applicator (2) with the screw (1).



### CAUTION!

Malfunctions by inadequate operational surface space.

- ⇒ Ensure a stable standing of the printer.

### 4.3 Pierce the Universal Tamp Pad

On the bottom of the pads there are holes for sucking and holding the labels by vacuum. When an universal tamp pad is delivered these holes are covered by the sliding foil and must be opened according to the label size. For that purpose a piercing pin is included in the contents of delivery.

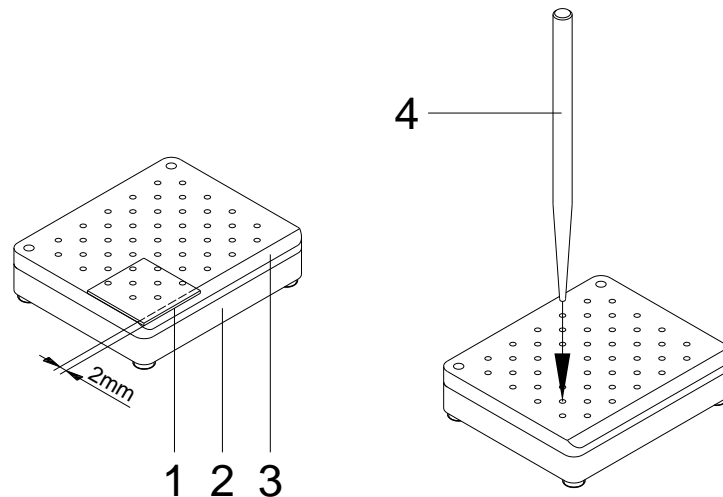

**Figure 10**

1. Place a label (1) to be operated on the bottom side of the pad (2). Note the position of the slanted edge (3).
2. Align the label to the side edge in such a way that it reaches over the rear edge of the pad by 2 mm.
3. Open all the holes, which are certainly covered by the label. Open the holes completely by turning the piercing pin (4) inside the holes.



**CAUTION!**

Malfunctions by a too weak vacuum.

- ⇒ Do not open holes which are located less than 1 mm from a label edge.

#### 4.4 Prepare for Using a Spring-Mounted Tamp Pad



##### NOTICE!

For using a spring-mounted universal tamp pad (> 90 x 120 mm) the fitting of the cylinder unit must be changed.

The cylinder unit (6) can be mounted on the bracket (1) in two different positions.

When the applicator is delivered, the cylinder unit is mounted on the bracket using the upper threaded hole (4). That position is suitable for the most pads.

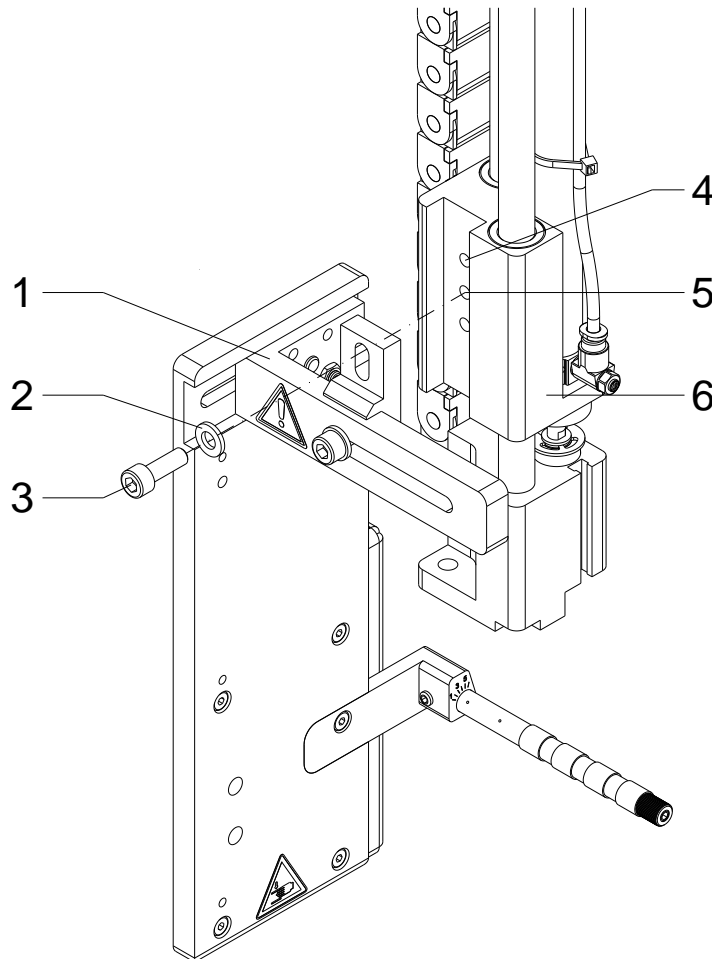

**Figure 11**

1. Loosen the screw (3) and washer (2).
2. Dismount the cylinder unit (6) from the connecting bracket (1).
3. Fasten the cylinder unit (6) to the connection bracket (1) with the screw (3) using the central hole (5). In rare cases, the lower hole can also be necessary.

## 4.5 Mount the Pad

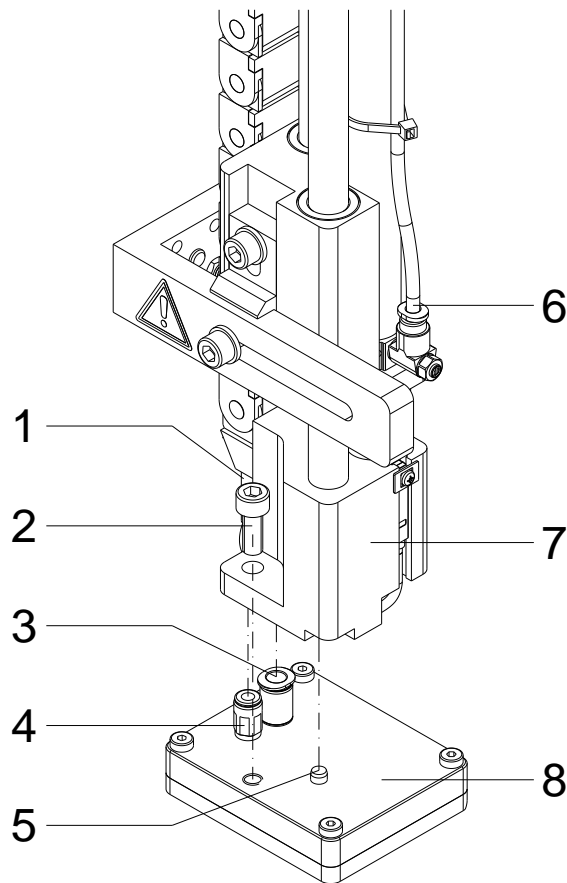

**Figure 12**

1. Pull the tube (6) out of the push-in-fitting.
2. Insert the pin (5) on the pad (8) into the hole on the bottom side of the pad holder (7).
3. Fix the pad (8) with the screw (2) at the pad holder (7) and make a rough adjustment of the pad to the printer dispensing plate.
4. Insert the vacuum tube (1) and the blowing air tube into the appropriate push-in-fittings (3,4) of the pad.
5. Insert the tube (6) into the appropriate push-in-fitting on the cylinder.



### CAUTION!

Danger of collision of the pad with other parts of the labelling system.

⇒ Before connecting the applicator to the compressed air supply please roughly align the pad in all directions..

## 4.6 Mount the Stopper



### NOTICE!

In the operating modes *Stamp on* and *Roll on* the stopper is not needed.

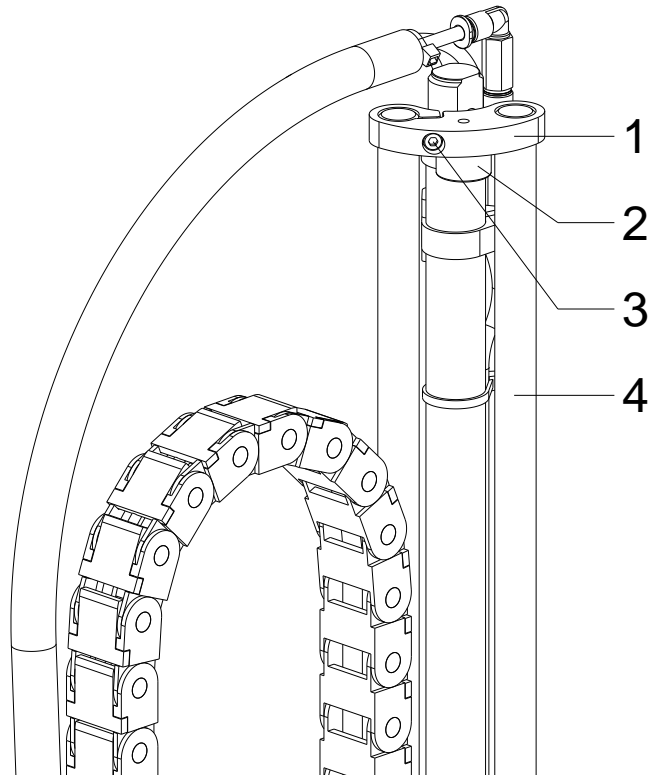

**Figure 13**

When the applicator is delivered, the stopper (1) is mounted on the rods (4). With this stopper the labelling position for the operation mode 'Blow on' can be adjusted.

### Operating mode 'Blow on'

1. Slide the stopper (1) with the rubber buffer (2) down onto the rods.
2. Adjust the stopper (1) (see chapter 7.5, page 37).

### Operating modes 'Stamp on' and 'Roll on'

In the operating modes 'Stamp on' and 'Roll on' the stopper is not needed. The stopper may not limit the pad movement.

1. Loosen the screw (3) at the stopper (1).
2. Slide the stopper (1) as far as possible upwards and tighten the screw (3).

or

3. Remove the stopper (1) upwards from the rods (4).

## 4.7 Connections

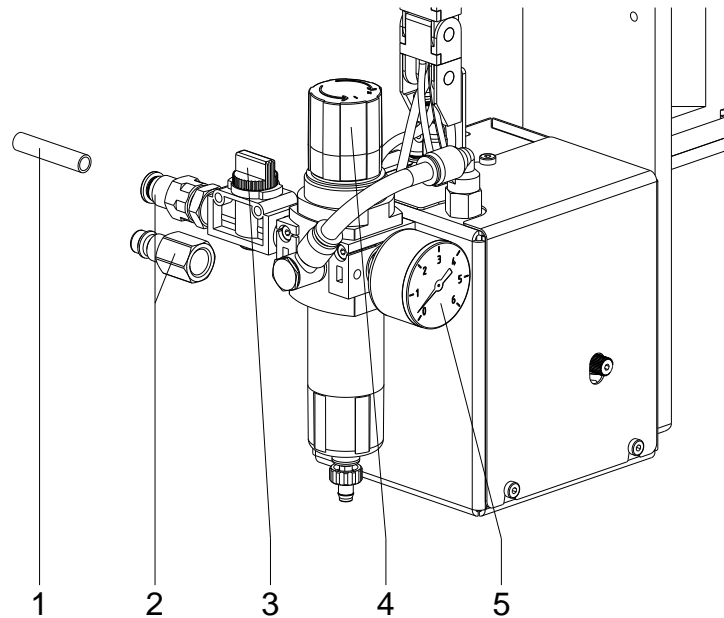

**Figure 14**

1. Prepare the printer connections to the power supply and to the computer (see operating manual of the label printer).
2. Close the shutoff valve (3 / lever at the valve is turned across the air flow direction).
3. Connect the applicator to the compressed air supply.  
The connector (2) for the compressed air supply is located at the rear of the service unit. The connector is suitable for a 1/4" coupling plug (1) or a tube with a diameter of 8 mm (appropriate coupling plug included).
4. The air pressure for operating the applicator is pre-adjusted to 0,5 MPa (5 bar). Check the pressure at the manometer (5) of the service unit. Correct the adjustment if necessary:
  - Pull knurled knob (4) up.
  - Turn knob to tune required operating pressure of 5 bar.
  - Push knob down.
5. Open the shutoff valve (3 / lever is turned in the air flow direction).
6. Switch on the power supply of the printer.



### CAUTION!

The pad will immediately be moved in the starting position.

- ⇒ Do not reach into the zone of the moving pad.
- ⇒ Keep long hair, loose clothes, and jewellery distant from the zone of the moving pad.
- ⇒ Do not reach or bend into the zone of the moving rods.





## 5 Configuration

The label applicator can be operated in diverse ways. While the original process stays the same, the operation mode can be chosen within the function menu of the connected label printer.

The most important setting is the selection between the operating modes 'Stamp on', 'Blow on' and 'Roll on'. Additionally the applicator has different application modes concerning the order of printing and applying within one labelling cycle.

	Stamp on	Roll on	Blow on
Print-Apply	✓	✓	✓
Apply-Print Waiting position up	✓	✓	✓
Apply-Print Waiting position down			✓

### 5.1 Configuration Parameter

Parameter	Meaning	Selection
Operating mode	Setting of operating mode Default: Stamp on	Stamp on, Blow on, Roll on
Mode	Setting of application mode Default: Print-apply	Print-apply Apply-print
Vacuum delay On	Setting of switch-on delay Vacuum Default: 0 ms	0 ... 2500 ms in 10 steps of ms
Vacuum delay Off	Setting of switch-off delay Vacuum Default: 500 ms	0 ... 5000 ms in steps of 10 ms
Support delay On	Setting of switch-on delay for supporting air Default: 0 ms	0 ... 2500 ms in steps of 10 ms
Support delay Off	Setting of switch-off delay for supporting air Default: 500 ms	0 ... 2500 ms in steps of 10 ms
Pressure control	Setting of compressed-air control Default: On	On Off
Vacuum control	Setting of vacuum control Default: On	On Off
Pressure time	Setting of pressure time Default: 100 ms	0 ...5000 ms in steps of 10 ms
Blow time	Setting of blow time Default: 100 ms	0 ... 2500 ms in steps of in 10 ms

Parameter	Meaning	Selection
Waiting position	Waiting position of pad with dispensed label for 'Blow on + Apply-print' Default: Up	Up Down
Roll on time	Setting of roll on time Default: 0 ms	0 ... 5000 ms in steps of 10 ms
Cleaning time	Setting of cleaning time Default: 100 ms	0 ... 2500 ms in steps of 10 ms
Timeout hub	Moving up/down of pad Default: 0 ms	0 ... 5000 ms in steps of 10 ms
Delay lower end position	Duration of the delay for the monitoring of sensor 'Lower end position' Default: 0 ms	0 ... 1000 ms in steps of 10 ms

## 5.2 Settings in Printer Function Menu

Switch on the label printer and the display shows the main menu.

Press the key **F** to access the function menu.

Press the key  until the menu *Label applicator* is displayed.

Press the key  to select the menu.

Press the key  to move to the next mode.

### Operating modes

#### Stamp on:

The label remains in a fixed position. The label is pressed directly onto the product.

#### Blow on:

The pad moves to a pre-adjusted position approximately 10 mm away from the product. The label is blown onto the product by an air jet stream. The print and apply cycle performs in a fixed position or in linear movement of the product.

#### Roll on:

The label is dispensed and moved until touching the roller of the roll on pad. In the labelling position, this roll is pressed onto the product. Then the label is applied and rolled on by the movement of product.

Press the key  to move to the next parameter.

### Application mode

The applicator can be operated in two different ways concerning the order of printing and labelling within one labelling cycle (see chapter 6, page 31).

#### Print-Apply:

The print of a label is released by an external start signal. At the same time, the vacuum on the pad as well as the supporting air from the blow tube are switched on. If the label is printed and picked up completely from tamp, the supporting air is switched off and the lift cylinder is controlled to move the pad down towards the labelling position. A sensor signals when the labelling position is reached. Following, the vacuum is switched off and the label is transferred to the product. After applying the label, the lift cylinder is so controlled that the pad is again moved back to the starting position. Now the labelling cycle is finished.

#### Apply-Print:

At the beginning of the cyclic operation 'Apply-Print' the first label is printed immediately and passed to the pad. The pad with the printed label is in starting position and the vacuum at the pad is switched on. At start of the cyclic operation when sending the start signal, the first label is already on the pad. The following process is similar to the mode 'print-apply' but at the end of the cycle the next label is printed and picked up by the pad. Now the labelling cycle is finished.

Press the key  to move to the next parameter.

### Vacuum delay On

The vacuum is not switched on immediately at print start, but only after the label has been feeded for a certain period. This delay causes the label to run under the pad more easily, as it is not immediately sucked in and thereby slowed down.

Value range: 0 ... 2500 ms

Step size: 10 ms

Default: 0 ms

Press the key  to move to the next parameter.





### Vacuum delay Off







The vacuum is not switched off immediately when the lower end position is reached, but only after the label has been pressed for a certain period. This delay ensures that the label does not move underneath the pad during stamping.

Value range: 0 ... 5000 ms

Step size: 10 ms

Default: 0 ms

- Press the key  to move to the next parameter.
- Support delay On**
- The supporting air from the blow tube is not immediately switched on at print start but only if the label has covered a distance. This delay helps to prevent a turning or swinging at the front of the label and consequently avoids faults when the label is being picked up from printer.  
Value range: 0 ... 2500 ms  
Step size: 0 ms  
Default: 0 ms
- Press the key  to move to the next parameter.
- Support delay Off**
- Delayed to the process of the label being picked up, the supporting air is switched off. In many cases, after being picked up by the pad the label edge may still stick on the liner. This may affect the accuracy of the label positioning or even cause faults in the labelling. Therefore, switching off the air blow delayed can be useful to separate the label from liner and place the label on the surface of pad.  
Value range: 0 ... 2500 ms  
Step size: 10 ms  
Default: 500 ms
- Press the key  to move to the next parameter.
- Pressure control**
- With activated compressed air control, with help from a compressed air sensor it is checked at each labelling cycle if the compressed air fits with the valve block. If no compressed air is presented, the labelling cycle is stopped and the error message 'compressed air' is displayed. If the parameter 'pressure control' is set to Off, the error treatment as described above will not be effected. This can be especially helpful for the initial operation of the labelling system. For standard operation, set the parameter to On.
- Press the key  to move to the next parameter.
- Vacuum control**
- The label transfer from printer to applicator is controlled by a vacuum sensor. If the transfer of label fails, the sucking holes on the pad will not be covered by the label and therefore no vacuum can originate on the pad. Afterwards an error message appears and the label strip will be fed back. If the parameter 'vacuum control' is set to Off, the error treatment as described above will not be effected. This can be especially helpful during adjustments, because the immediate backfeed will be cancelled and therefore it is easier to check the reasons for the faulty transfer. For standard operation, set the parameter to On.
- Press the key  to move to the next parameter.
- Pressure time**
- This parameter is only active if the operating mode 'stamp on' is selected. The time can be adjusted while the pad is kept in the labelling position for applying the label onto the goods.

- Press the key  to move to the next parameter.
- Blow time**  
 This parameter is only active if the operating mode 'blow on' is selected. The time can be adjusted, while the blowing air is switched on for transferring the label onto product.  
 Value range: 0 ... 2500 ms  
 Step size: 10 ms  
 Default: 100 ms
- Press key  to arrive the next parameter.
- Waiting position**
-  **NOTICE!**  
 This parameter is only active if the operating mode 'blow on' and mode 'apply-print' are selected.
- Waiting position up:**  
 In cyclic mode the pad with the printed label waits in the labelling position near the dispensing edge of printer for the external start signal.
- Waiting position down:**  
 In cyclic mode the printed label is transported to the labelling position at the end of a cycle.  
 So the next cycle begin with blowing up the label.
- Press the key  to move to the next parameter.
- Roll on time**  
 This parameter is only active if the operating mode 'blow on' is selected. The time period can be adjusted while the roll on pad is stopped in labelling position.  
 Value range: 0 ... 5000 ms  
 Step size: 10 ms  
 Default: 0 ms
- Press the key  to move to the next parameter.
- Cleaning time**  
 This parameter is only active if the operating mode 'blow on' and 'roll on' are selected. The time can be adjusted for the cleaning period of pad after application procedure.  
 Value range: 0 ... 2500 ms  
 Step size: 10 ms  
 Default: 100 ms
- Press the key  to move to the next parameter.
- Stroke timeout**  
 Moving up and down of pad.  
 If the pad does not reach the corresponding final position within the set time, then an error message appears ('final position above' at moving up and/or 'final position below' at moving down).  
 Value range: 0 ... 5000 ms  
 Step size: 10 ms  
 Default: 0 ms

**Delay lower end position**

Press the key  to move to the next parameter.

The reaching of the lower end position within the labelling cycle is not checked immediately after the start of the downward movement, but only when the pad has moved downwards for a certain time. This ignores an erroneous release of the lower end position (e.g. by inertia of the pad).

Value range: 0 ... 1000 ms

Step size: 10 ms

Default: 0 ms

Press the key  to move to the next parameter.





**Test functions****Stroke adjust**

The arrester can be adjusted and the stroke speed can be set. The pad makes a stroke movement and return to the basic position after reaching the lower end position.

Press the key  to start the stroke movement.

Press the key  to move to the next parameter.

**Input/Output**

This menu serves for the applicator setup as well as for error tracing. Input signals of the applicator can be monitored and output signals can be set or reset separately. Press the keys  and  to select the corresponding output for set/reset the output signals. Press the keys  and  to set/reset the corresponding output.

**Input signals**

- I1 = Pre-dispense key (1 = key pressed, 0 = key not pressed)
- I2 = Final position up (1 = pad in final position up, 0 = pad not in final position up)
- I3 = Final position down (1 = pad in final position down, 0 = pad not in final position down)
- I4 = Compressed air (1 = compressed air available, 0 = no compressed air available)
- I5 = Vacuum (1 = vacuum at pad available, 0 = no vacuum at pad available)

**Output signals**

- 1 = Move pad downwards (1 = On, 0 = Off)
- 2 = Move pad upwards (1 = On, 0 = Off)
- 3 = not assigned
- 4 = not assigned
- 5 = Blowing air (1 = On, 0 = Off)
- 6 = Supporting air (1 = On, 0 = Off)
- 7 = Vacuum pad (1 = On, 0 = Off)

## 6 Signal Diagrams

### 6.1 Print - Apply

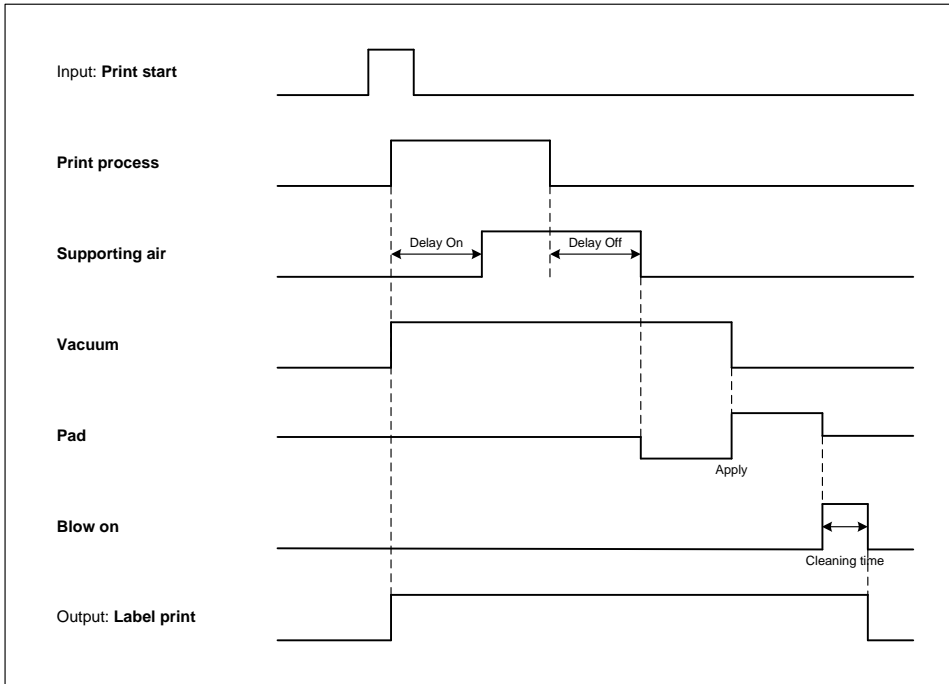

Figure 15

### 6.2 Apply - Print

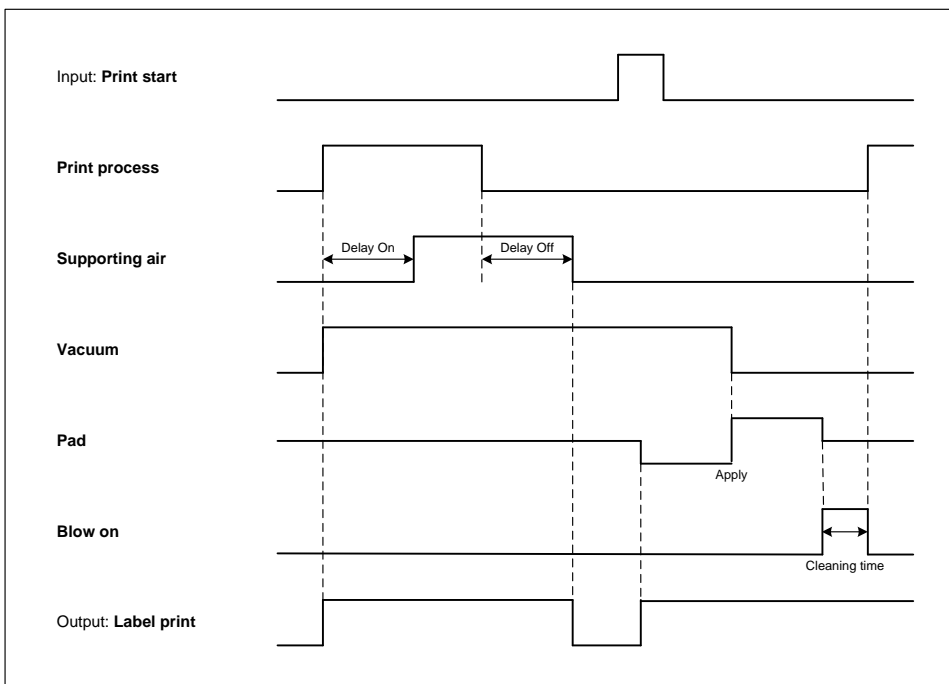

Figure 16





## 7 Mechanical Adjustments



### NOTICE!

Perform the mechanical adjustments in two steps

- ⇒ Roughly align the pad in all directions to avoid collisions of the pad with other parts when switching on the compressed air.
- ⇒ Perform the fine adjustment with compressed air switched on to optimize the labelling process.

### 7.1 Align the Pad

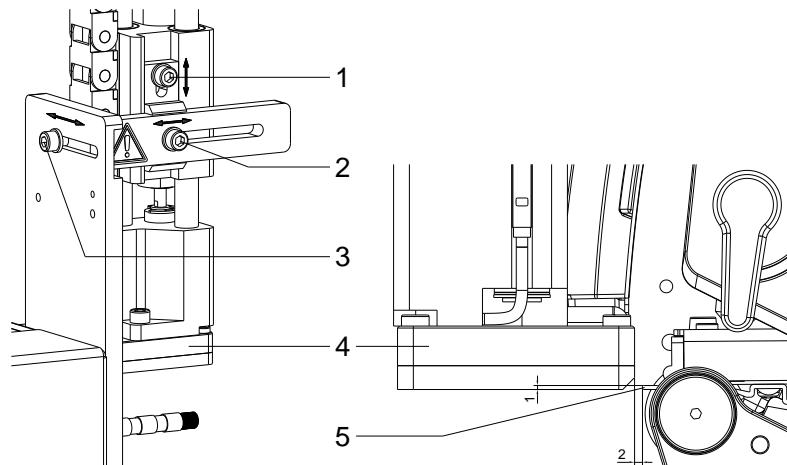

Figure 17

#### Adjustment in print direction

1. Loosen the screw (3).
2. Shift the cylinder unit including the pad (4) inside the elongated hole in such a way, that the distance between the pad and the dispensing edge (5) is about 2 mm.
3. Tighten the screw (3).

#### Height adjustment

1. Loosen the screw (1).
2. Shift the cylinder including the pad (4) inside the elongated hole in such a way that the lower rear edge of the pad (4) is located about 1 mm below the dispensing edge (5) of the printer.
3. Tighten the screw (1).

**Side adjustment**

1. Loosen the screw (2).
2. Shift the cylinder unit including the pad (4) inside the elongated hole in such a way, that the dispensed label is aligned centrally to the pad respectively to the open holes in an universal pad.
3. Tighten the screw (2).

**NOTICE!**

Check the adjustment with compressed air switched on.

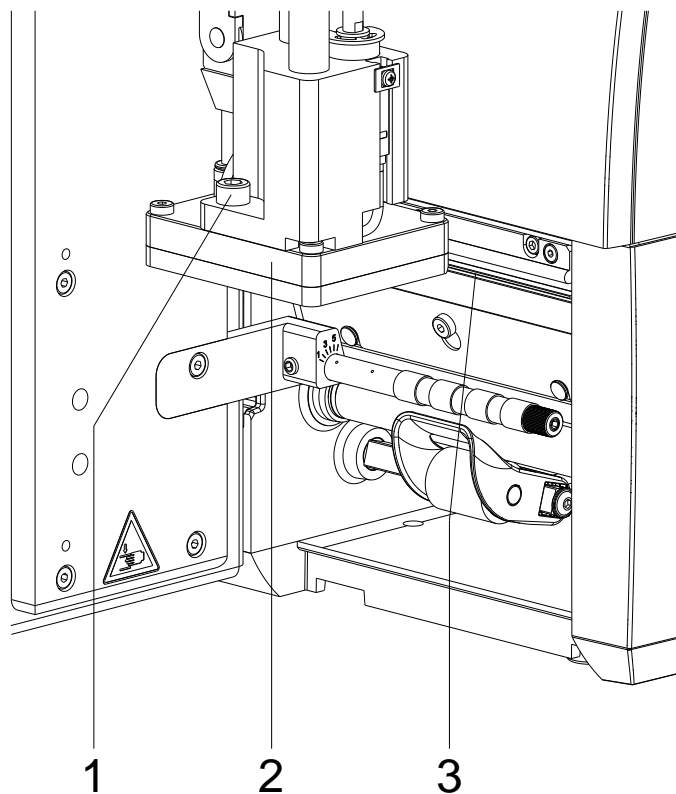
**7.2 Adjust the Parallelism between Pad and Dispensing Edge****Figure 18**

1. Loosen the screw (1).
2. Adjust the parallelism between the rear edge of the pad (2) and the dispensing edge (3) by turning the pad.
3. Tighten the screw (1).

### 7.3 Open the Holes on the Blow Tube

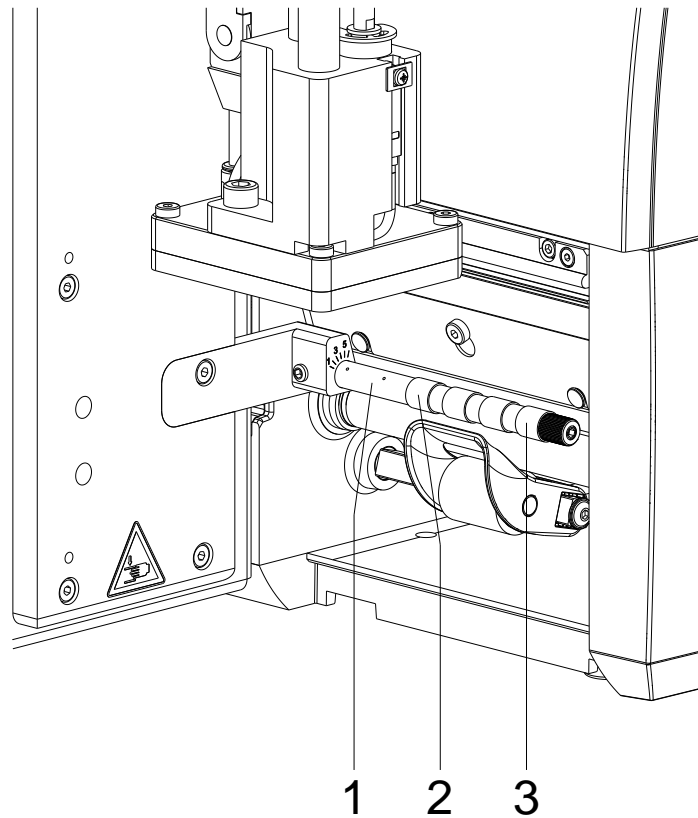

**Figure 19**

1. The blow tube (1) has holes for the supporting air in regular distances of 15 mm.
2. When the applicator is delivered only the two inner holes are open. The other holes are closed by plastic rings (3).
3. To adjust the supporting air to the label width, the plastic rings (2) can be removed from the holes.
4. Open all holes, which affect certainly the area of the label.

### 7.4 Align the Blow Tube

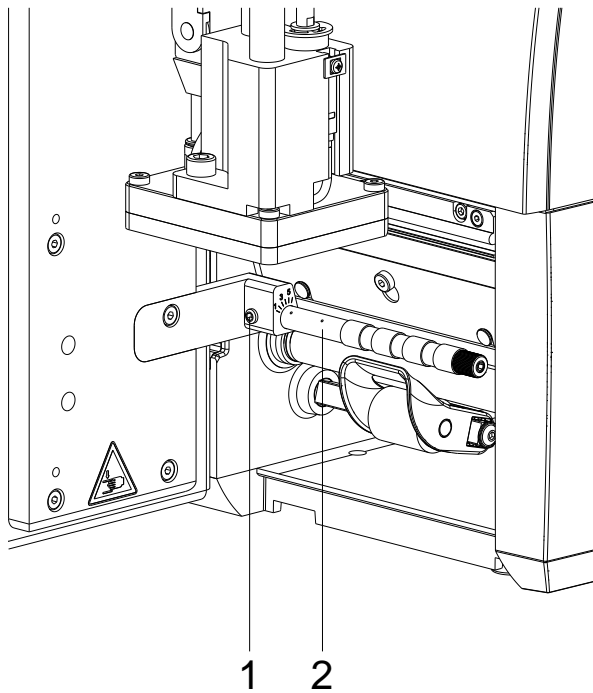

The blow tube (2) for the supporting air can be rotated around its axis. That way the direction of the supporting air can be optimized.

1. Loosen screw (1).
2. Turn the blow tube (2) in that direction that the air current supports the sucking of the label by the pad.

Figure 20

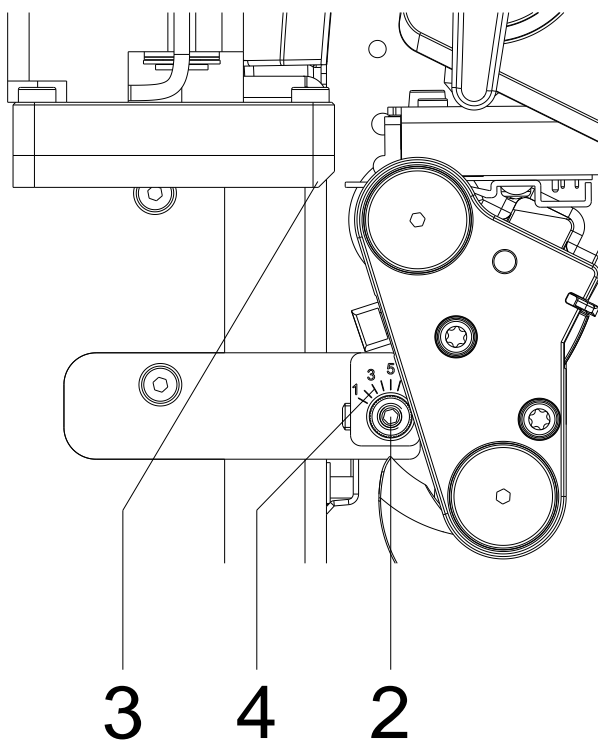

1. For small labels direct the air current to the dispensing edge (3) of the printer (setting 3 or 4 at the scale).
2. For larger labels direct the air current away from the dispensing edge (3 / setting 1).
3. Tighten screw (1).

Figure 21

## 7.5 Adjust the Stopper

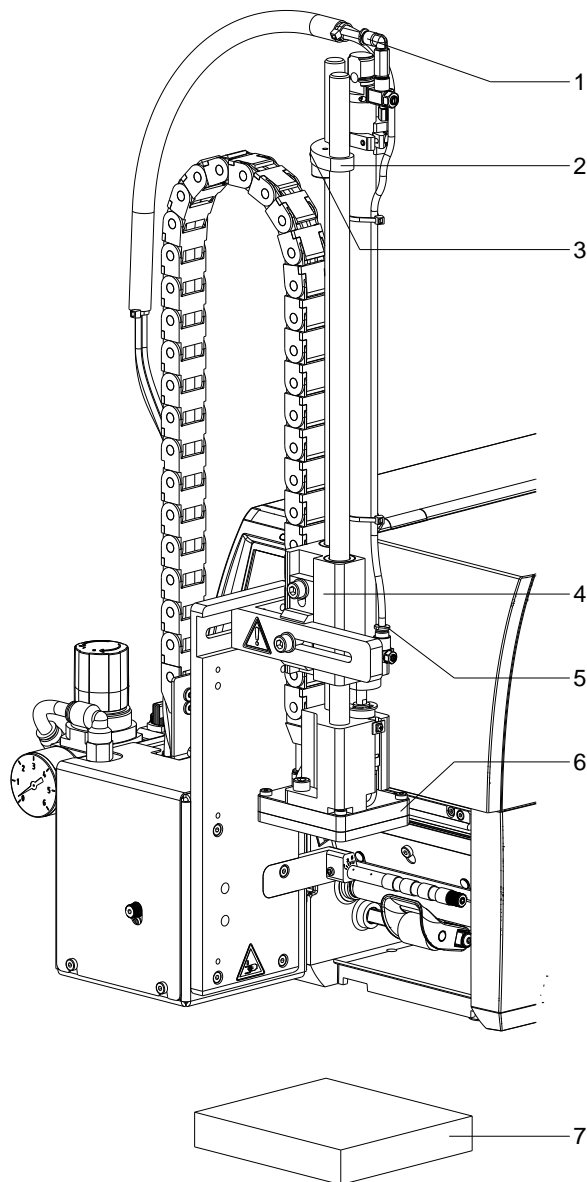

### NOTICE!

For operating mode *Blow on* only.



### CAUTION!

Danger of injury by inadvertent move out of the cylinder.

⇒ Switch off the printer and close the shutoff valve for the compressed air at the service unit.

1. Place a product sample (7) at the labelling point.
2. Pull the tubes out of the push-in-fittings (1,5).
3. Loosen the screw (3) in the stopper (2).
4. Move the pad manually in the required labelling position. The distance between the blow pad (6) in the labelling position and the product surface (7) must not exceed 10 mm.
5. Move the stopper (2) against the guide block (4) and tighten the screw (3).
6. Insert the tubes into the appropriate push-in-fittings (1,5).
7. Open the shutoff valve and switch on the printer.

Figure 22



## 8 Pneumatic Adjustments

### 8.1 Control Valves

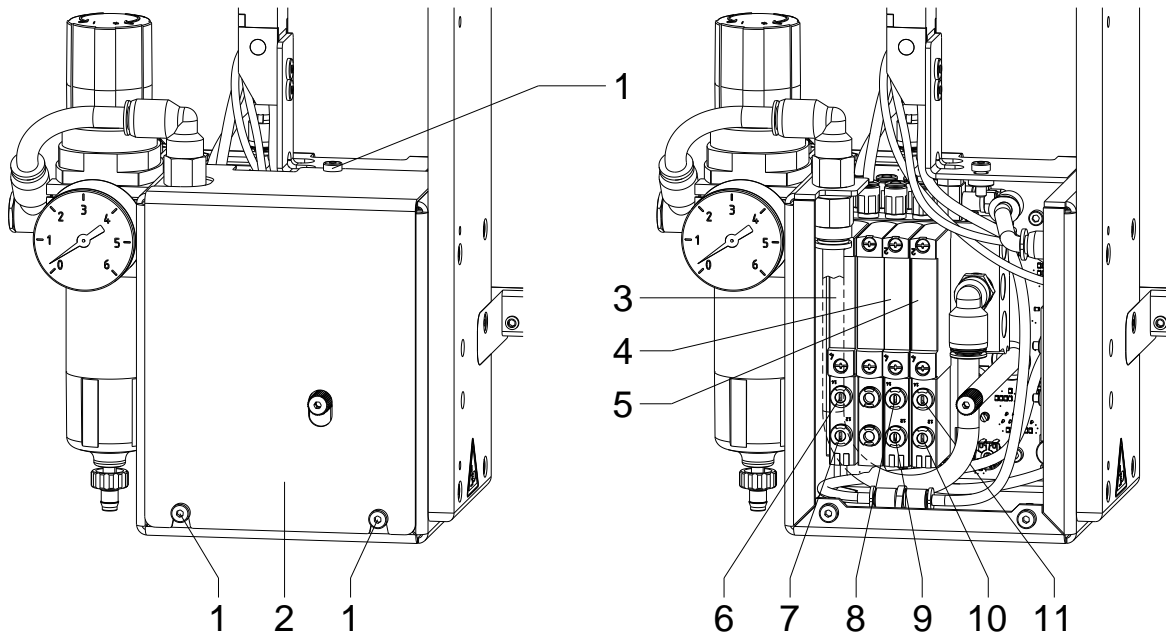

Figure 23

For adjustments of certain applicator functions, release the control valves in the pneumatic system.

- ⇒ Loosen screws (1) and remove cover (2).
- ⇒ The compressed air control valves can be controlled manually with integrated switch.

#### 3-way valve (3) to control the lift cylinder

If the printer is switched on the valve will be controlled by electronics and the tamp will hold in the upper end position (home position). If the valve is switched the tamp will move in the lower end position (labelling position).

In normal labelling operation the movement back in the upper end position will start by a signal from the labelling sensor.



#### NOTICE!

The switching by hand of this valve has only a result in case of a switched off printer.

Switching the valve by hand over switch 7 the tamp will move down up to the lowest possible position because no control is made by the sensor.

Switching the valve by hand over switch 7 the tamp will move up.

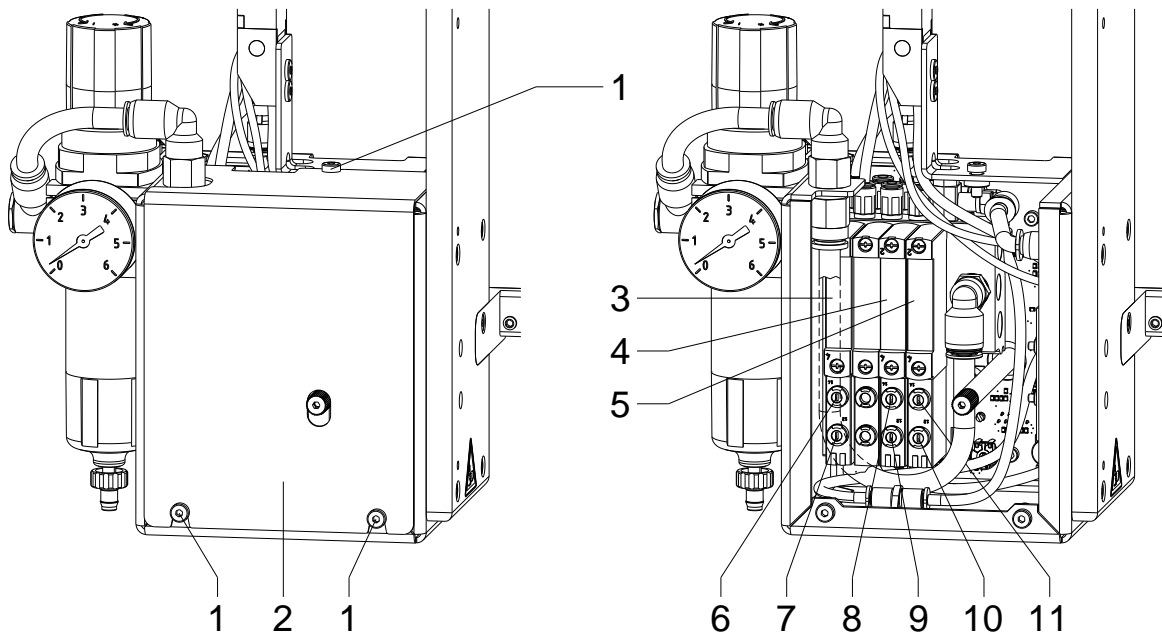

Figure 24

#### Double 2-way valve (4) for blow air

In the operation mode 'Blow on' the label will blow up to the product.

In the operating modes 'Stamp on' and 'Roll on' the blow air is switched on for a short time after each application to avoid contaminations within the vacuum channels.

For all described functions both valves will be controlled parallel.

By pressing the keys 8 or 9 the blow air is only switched on by one of both internal valves.

#### Double 2-way valve (5) for vacuum / supporting air

The two internal valves serve the vacuum nozzle for connecting an in this way for creating the negative pressure at the tamp and independent of this for connecting the support air at the blow tube for the label transfer.

By pressing switch 10 the vacuum is switched on and by pressing switch 11 the supporting air is switched on.



## 8.2 Adjust the Pad Movement Speed

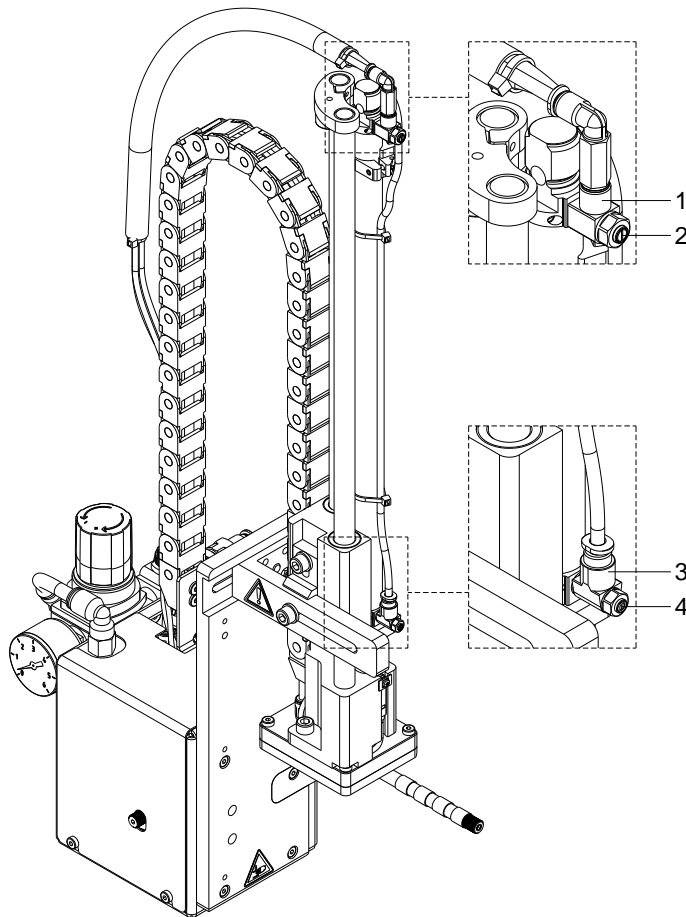

The adjustment of pad movement speed can be regulated with two throttle valves (1, 3).

- ⇒ Adjust the pad movement speed, as necessary.
- ⇒ To increase the downward speed turn the screw (4) at the lower valve (3) anticlockwise.
- ⇒ To increase the upward speed turn the screw (2) at the upper valve (1) anticlockwise.

Figure 25



### NOTICE!

The application pressure of the pad is dependent on the downward speed of the pad.

- ⇒ To reduce the application pressure turn screw (4) in clockwise direction.



### CAUTION!

A too high decrease of the downward speed leads to an error message (Error 101 - Lower position).

- ⇒ The downward movement may not need more time as specified in the menu *Timeout Hub* (see page 29).

### 8.3 Adjust Vacuum and Supporting Air

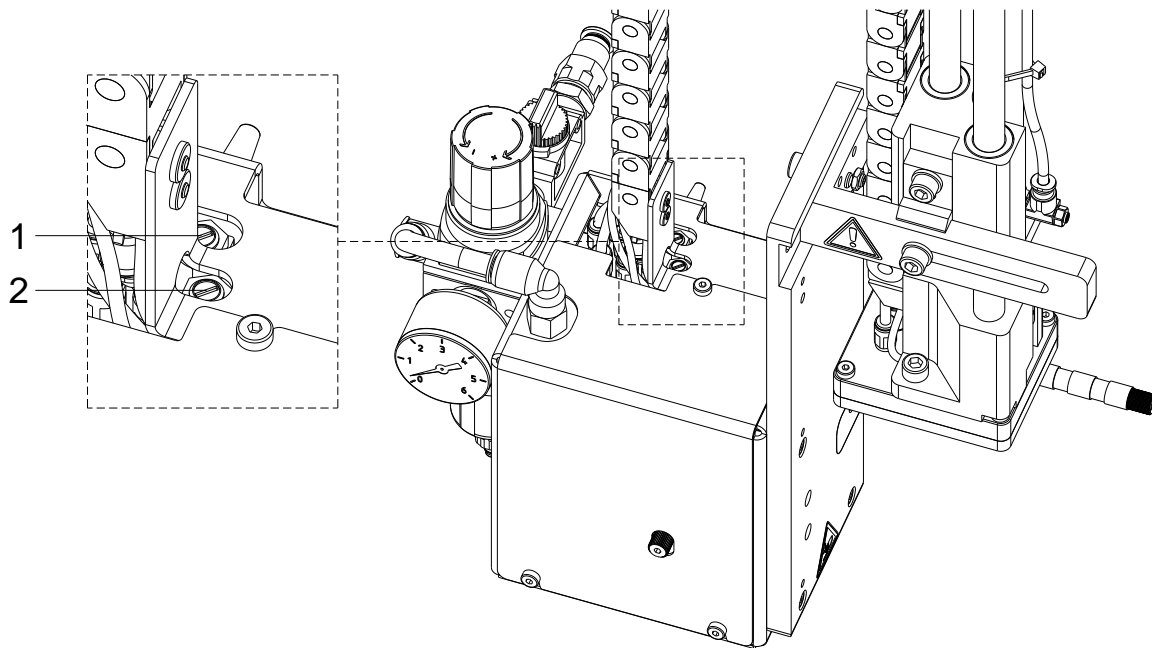

Figure 26

#### Adjusting the supporting air

With the valve (1) the supporting air for blowing the label to the pad can be varied.

- ⇒ Adjust the supporting air in such way that the label is blown on the pad without swirling.
- ⇒ To increase the supporting air turn the screw at the valve (1) anticlockwise.
- ⇒ If necessary adjust the direction of the air current (see chapter 7.4 page 35).

#### Adjusting the vacuum



#### NOTICE!

With the vacuum setting the final position of the label on the pad can be adjusted. If the vacuum is too high the label feeding may early be stopped.

With the valve (2) the vacuum for sucking the label to the pad can be varied.

- ⇒ Adjust the vacuum in such way that the label is correctly sucked.
- ⇒ To increase the vacuum turn the screw at the valve (2) anticlockwise.

## 9 Operation

### 9.1 Load the Label Material



#### NOTICE!

In dispenser mode the labels are removed after printing, and only the liner is wound up internally.

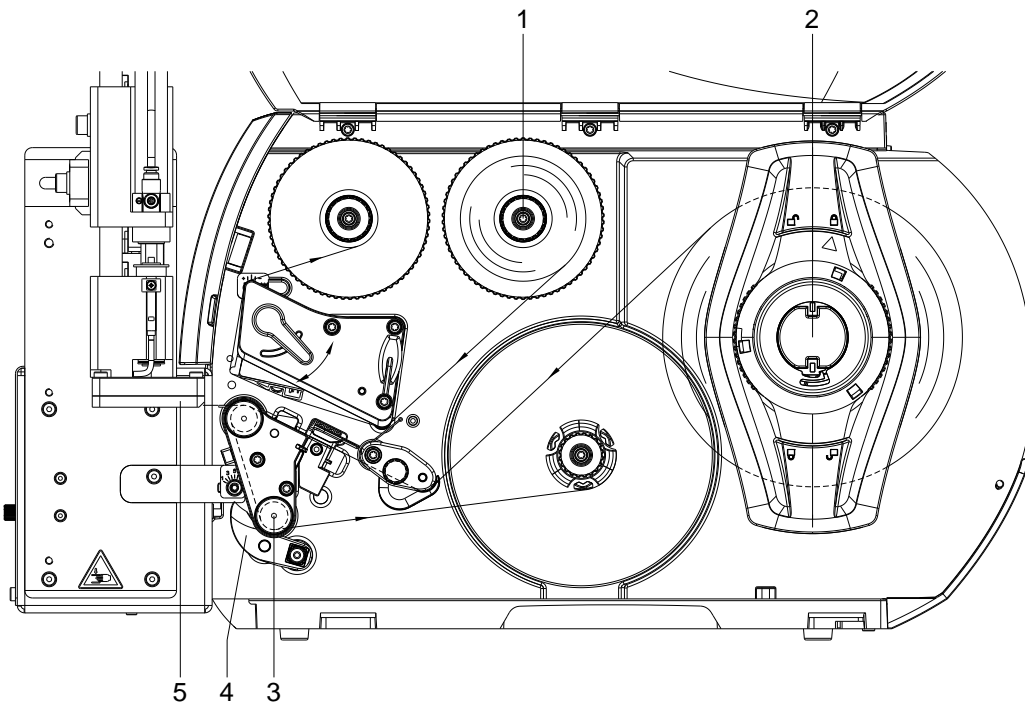

Figure 27



#### NOTICE!

For detailed information about inserting the material please read the operating manual of the label printer.

- ⇒ Insert the transfer ribbon (1).
- ⇒ Insert the label material.



#### CAUTION!

Collision between the pad (5) and the locking system (4) during the labelling procedure.

- ⇒ Swivel the locking system (4) on the rewind assistant roller (3).

## 9.2 Set the Dispenser Mode



### NOTICE!

To operate the label printer in dispenser mode a print order must be started and the printer is to be in 'waiting' mode.

Switch on the label printer and the display shows the main menu.

Press the key to access the function menu.

Press the key until the menu *Dispenser I/O* is displayed.

Press the key to select the menu.

In the upper line of the display, the operating mode can be selected.

In the line below, the dispenser I/O offset (approx. 18 mm) can be set.

Press the key to move to the next operating mode.

### Operating modes

#### Off:

It is printed without the labels are dispensed.

#### I/O static:

The input signal evaluated, i.e. it is printed as long as the signal exists. The number of labels which was entered at the print start is printed.

The set dispenser offset is not taken into consideration.

#### I/O static continuous:

For description of this operating mode, see I/O static.

Continuous means that it is printed if new data is transferred via interface

The set dispenser offset is not taken into consideration.

#### I/O dynamic:

The external signal is evaluated dynamically, i.e. is the printer in 'waiting' mode a single label is printed at each signal changing. After the print the set dispenser offset is executed, i.e. a backfeed is effected.

#### I/O dynamic continuous:

For description of this operating mode, see I/O dynamic.

Continuous means that it is printed if new data is transferred via interface.

#### Photocell:

The printer is controlled via photocell. The printer prints automatically a label if the user takes away the label at the dispensing ledge. The print order is finished when the target number of labels is reached.

#### Photocell continuous:

For description of this operating mode, see Photocell.

Continuous means that it is printed if new data is transferred via interface.

### 9.3 Initial Operation

1. Check all external connections (see chapter 4.7, page 23).
2. Load the transfer ribbon and the label material (see chapter 9.1, page 43).

**NOTICE!**

Ensure that the locking system (4, Figure 27) is closed.

3. Open the shutoff valve.

**CAUTION!**

If the pad is covered the vacuum sensor may be calibrated faultily.

⇒ Before switching on the printer-applicator system ensure that the pad is not covered.

4. Switch on the label printer.

**CAUTION!**

The pad will immediately be moved in the starting position.

⇒ Do not reach into the zone of the moving pad.

⇒ Keep long hair, loose clothes, and jewellery distant.

⇒ Do not reach or bend into the zone of the moving rods.

5. Press the key  at the printer.  
A synchronization feed is released. The processed labels must be removed manually. After a few seconds, the printer conducts a short backfeed to position the front edge of the next label at the printing line.

**NOTICE!**

This synchronizing also must be conducted when the print job has been interrupted with the key .

Synchronizing is not necessary when the printhead was not lifted between print jobs. This also applies if the printer was powered off between print jobs.





6. Start a print job.



## 10 Error Messages

### 10.1 Error Messages of the Printer

In case an error occurred the printer stops and the print order is interrupted. Information to causes and remedies of printer errors e.g. *no label found* are to be taken from the printer manual.

1. Clear the error.
2. Press the key  to synchronize the label feed.
3. Remove the peeled labels manually.
4. Press the key  to quit the error state.
5. Press the key  to continue the print order or press the key  to cancel the print order.

### 10.2 Error Messages of the Applicator

Error message	Cause	Remedy
Upper position	The upper position (start position) was not reached.	Check final position switch for start position and compressed-air supply. Adjust stroke timeout.
Lower position	The lower position (labelling position) was not reached.	Check final position switch for labelling position and compressed-air supply. Adjust stroke timeout.
Empty vacuum plate	The sensor does not recognize a label at the vacuum plate.	Check if all holes of the pad plate are covered from the label. Check compressed-air supply.
Print position	At print start the pad is not in printing position (upper pad position).	Check the correct function and position of the final position switch for the upper position (start position). Check the pneumatic function.



#### CAUTION!

The pad will immediately be moved in the starting position.

- ⇒ Do not reach into the zone of the moving pad.
- ⇒ Keep long hair, loose clothes, and jewellery distant from the zone of the moving pad.
- ⇒ Do not reach or bend into the zone of the moving rods.

After error correction, the print of the label causing the error cannot be repeated without re-start of the print order.





## 11 Environmentally Friendly Disposal

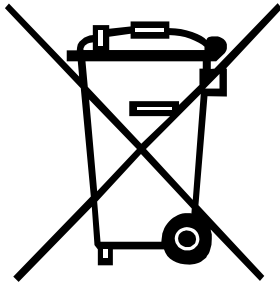

Manufacturers of B2B equipment are obliged to take-back and dispose old equipment which was manufactured after 13 August 2005. In principle, this old equipment may not be delivered to communal collecting points. They may only be organised used and disposed by the manufacturer. Valentin products accordingly labelled can therefore in future be returned to Carl Valentin GmbH.

This way, you can be sure your old equipment will be disposed of correctly.

Carl Valentin GmbH thereby fulfils all obligations regarding timely disposal of old equipment and facilitates the smooth reselling of these products. Please understand that we can only take back equipment that is sent free of carriage charges.

The electronics board of the printing system is equipped with a battery. This must only be discarded in battery collection containers or by public waste management authorities.

Further information on the WEEE directive is available on our website [www.carl-valentin.de](http://www.carl-valentin.de).



## 12 Index

<b>B</b>	
blow tube, adjusting.....	36
<b>C</b>	
configuration	
operating mode.....	25
parameter.....	25
connections.....	23
control valves.....	39, 40
<b>D</b>	
device overview	
front view.....	13
rear view.....	14
dispenser mode.....	44
<b>E</b>	
environmentally-friendly disposal.....	49
error messages	
applicator.....	47
printer.....	47
<b>F</b>	
function menu (printer)	
application modes.....	27
blow time.....	29
cleaning time.....	29
delay lower end position.....	30
input/output.....	30
operating modes.....	26
pressure control.....	28
pressure time.....	28
roll on time.....	29
stroke timeout.....	29
support delay Off.....	28
support delay On.....	28
test functions.....	30
vacuum control.....	28
vacuum delay off.....	27
vacuum delay on.....	27
waiting position.....	29
<b>H</b>	
holes (blow tube), opening.....	35
<b>I</b>	
instructions.....	5
intended use.....	6
<b>L</b>	
label application.....	11
label material, loading.....	43

<b>M</b>	
mounting to printer .....	18
<b>O</b>	
operating conditions .....	9, 10
<b>P</b>	
pad	
adjusting .....	34
aligning, height adjustment .....	33
aligning, in print direction .....	33
aligning, side adjustment .....	34
blow pad .....	15
mounting .....	21
movement speed .....	41
roll-on pad .....	15
tamp pad .....	15
product description .....	11
<b>S</b>	
safety instructions .....	7
safety labels .....	8
scope of delivery .....	17
signal diagrams	
apply-print .....	31
print-apply .....	31
standard operation .....	45
stopper	
adjusting .....	37
mounting .....	22
supporting air, adjusting .....	42
<b>T</b>	
technical data .....	12
<b>U</b>	
universal tamp pad	
piercing (standard tamp pad) .....	19
preparing (spring-mounted tamp pad) .....	20
<b>V</b>	
vacuum, adjusting .....	42





---

Carl Valentin GmbH  
Neckarstraße 78 – 86 u. 94 . 78056 Villingen-Schwenningen  
Phone +49 7720 9712-0 . Fax +49 7720 9712-9901  
info@carl-valentin.de . www.carl-valentin.de