

APX 7000

Operating Manual



Copyright by Carl Valentin GmbH / 7997505.1023

Information on the scope of delivery, appearance, performance, dimensions, and weight reflect our knowledge at the time of printing.

We reserve the rights to make modifications.

All rights, including those regarding the translation, are reserved.

No part of this document may be reproduced in any form (print, photocopy, or any other method) or edited, copied, or distributed electronically without written permission from Carl Valentin GmbH.

Due to the constant further development of our devices discrepancies between manual and device can occur.

Please check www.carl-valentin.de for the latest update.

Trademarks

All named brands or trademarks are registered brands or registered trademarks of their respective owners and may not be separately labelled. It must not be concluded from the missing labelling that it is not a registered brand or a registered trademark.

The applicator comply with the following safety guidelines:

CE Electromagnetic Compatibility Directive (2014/30/EU)
EG Machinery Directive (2006/42/EG)



Carl Valentin GmbH

Postfach 3744
78026 Villingen-Schwenningen
Neckarstraße 78 – 86 u. 94
78056 Villingen-Schwenningen

Phone +49 7720 9712-0
Fax +49 7720 9712-9901

E-Mail info@carl-valentin.de
Internet www.carl-valentin.de

Table of Contents

| | | |
|-----------|---|-----------|
| 1 | Introduction..... | 5 |
| 1.1 | General Instructions | 5 |
| 1.2 | Intended Use | 6 |
| 2 | Safety Instructions | 7 |
| 2.1 | Safety Marking..... | 8 |
| 2.2 | Operating Conditions..... | 9 |
| 3 | Product Description | 13 |
| 3.1 | Apply the Labels | 13 |
| 3.2 | Applicator Overview..... | 14 |
| 3.3 | Pads | 17 |
| 3.4 | Remove the Covers..... | 18 |
| 4 | Technical Data | 19 |
| 5 | Installation..... | 21 |
| 5.1 | Scope of Delivery | 21 |
| 5.2 | Install the Applicator to the Printing System..... | 22 |
| 5.3 | Pierce the Universal Tamp Pad..... | 23 |
| 5.4 | Prepare for Using a Sprint-Mounted Tamp Pad..... | 24 |
| 5.5 | Install the Pad..... | 25 |
| 5.6 | Install the Connections | 26 |
| 6 | Options | 27 |
| 6.1 | Quick Apply | 27 |
| 6.2 | Shock Absorber..... | 28 |
| 6.3 | Product Sensor..... | 29 |
| 7 | Configuration | 31 |
| 7.1 | Configuration Parameter | 31 |
| 7.2 | Settings in Printing System Function Menu | 33 |
| 8 | Signal Diagrams | 39 |
| 8.1 | Print – Apply (w/o transverse axis)..... | 39 |
| 8.2 | Apply – Print (w/o transverse axis)..... | 40 |
| 9 | Mechanical Adjustments | 41 |
| 9.1 | Align the Pad | 41 |
| 9.2 | Adjust the Parallelism between Pad and Dispensing Edge .. | 43 |
| 9.3 | Open the Holes on the Blow Tube | 43 |
| 9.4 | Align the Blow Tube | 44 |
| 9.5 | Adjust the Stopper..... | 45 |
| 10 | Pneumatic Adjustments | 47 |
| 10.1 | Control Valves | 47 |
| 10.2 | Adjust the Pad Movement Speed..... | 49 |
| 10.3 | Adjust the Vacuum and Supporting Air | 50 |
| 11 | Operation..... | 53 |
| 11.1 | Load Labels and Transfer Ribbon | 53 |
| 11.2 | Set the Dispenser Mode..... | 54 |
| 11.3 | Standard Operation | 55 |
| 12 | Applicator Interface..... | 57 |
| 12.1 | Printer internal circuitry..... | 58 |
| 12.2 | Pin assignment D-Sub bushing..... | 59 |
| 12.3 | Examples..... | 61 |
| 12.4 | Precautions..... | 62 |

| | | |
|-----------|--|-----------|
| 13 | Error Messages | 63 |
| 13.1 | Error Messages of the Printing System..... | 63 |
| 13.2 | Error Messages of the Applicator | 63 |
| 13.3 | Troubleshooting pressure /vacuum control | 64 |
| 14 | Environmentally-Friendly Disposal | 67 |
| 15 | Index | 69 |

1 Introduction

1.1 General Instructions

Basic information and warning references with the corresponding signal words for the danger level are as follows specified in this manual:



DANGER identifies an extraordinarily great and immediate danger which could lead to serious injury or even death.



WARNING identifies a possible danger could lead to serious bodily injury or even death if sufficient precautions are not taken.



WARNING of cutting injuries.
Pay attention that cutting injuries caused by blades, cutting devices or sharp-edged parts are avoided.



WARNING of hand injuries.
Pay attention that hand injuries caused by closing mechanical parts of a machine/equipment are avoided.



WARNING of hot surfaces.
Pay attention so as not to come into contact with hot surfaces.



CAUTION indicates a potentially dangerous situation which could lead to moderate or light bodily injury or damage to property.



NOTICE gives you tips. They make a working sequence easier or draw attention to important working processes.



Gives you tips on protecting the environment.



Handling instruction



Optional accessories, special fittings

Date

Information in the display

1.2 Intended Use

The print module is a state-of-the-art device which complies with the recognized safety-related rules and regulations. Despite this, a danger to life and limb of the user or third parties could arise and the print module or other property could be damaged while operating the device.

The print module may only be used while in proper working order and for the intended purpose. Users must be safe, aware of potential dangers and must comply with the operating instructions. Faults, in particular those which affect safety, must be remedied immediately.

The print module is solely intended to print suitable media which have been approved by the manufacturer. Any other or additional use is not intended. The manufacturer/supplier is not liable for damage resulting from misuse. Any misuse is at your own risk.

Intended use includes heeding the operating manual, including the maintenance recommendations/regulations specified by the manufacturer.

2 Safety Instructions

- Before mounting the delivered components disconnect the printing system from the power supply and close the shutoff valve at the applicator.
- Couple the applicator to devices using extra low voltage only.
- Before making or undoing connections, switch off all devices involved (computer, printer, accessories etc.).
- In operation, moving parts are easily accessible. This applies especially for the zone, where the pad is moved between the starting and the labelling position. During operation do not reach into that zone and keep long hair, loose clothes, and jewellery distant.
Before any manipulations in those areas, close the shutoff valve.
- Operate the applicator in a dry environment only and do not get it wet (sprayed water, mist etc.).
- Do not operate the applicator in explosive atmosphere and not in proximity of high voltage power lines.
- Operate the applicator only in an environment protected against abrasive dust, swarf and other similar impurity.



NOTICE!

With the open printing unit (due to construction) the requirements of EN 62368-1 regarding fire protection casing are not fulfilled. These must be ensured by the installation into the end device.

- Maintenance and servicing work can only be carried out by trained personnel.
- Operating personnel must be trained by the operator on the basis of the operating manual.
- Carry out only the actions described in these operating instructions. Any work beyond this may only be performed by especially trained personnel or service technicians.
- Unauthorized interference with electronic modules or their software can cause malfunctions.
- Other unauthorized work or modifications to the applicator can endanger operational safety.
- There are warning stickers on the applicator that draw your attention to dangers. Therefore the warning stickers are not to be removed as then you and others cannot be aware of dangers and may be injured.
- When incorporating the unit into the overall system, make sure that safety precautions are taken so that no-one is able to reach into the working area.



CAUTION!

Damages of the plunger rod, cylinder tube or the seals caused by lateral forces that affect the plunger rod of the cylinder. This can lead to a reduction of lifetime and to leakages up to destruction of the cylinder.

⇒ Lateral forces must be avoided necessarily.

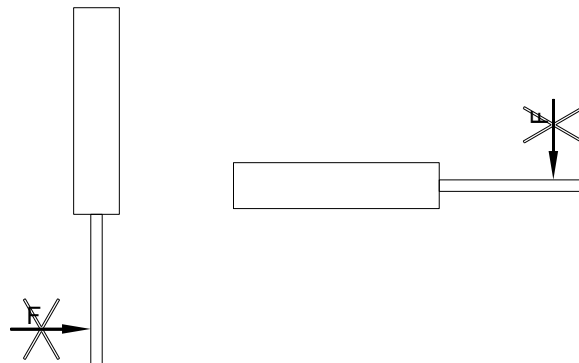

2.1 Safety Marking

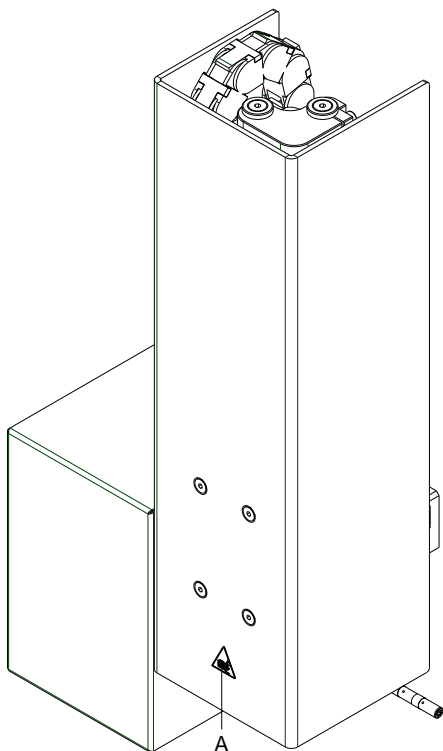

CAUTION!

There is a risk of injury due to the movement of the pad downwards and back up again.

- ⇒ Do not reach into the working area of the pad.
- ⇒ Keep hair, loose clothing and items of jewellery out of this area.
- ⇒ When incorporating the unit into the overall system, safety precautions must be taken so that no-one is able to reach into the working area.

A = Risk of crushing due to the movement of the pad

Figure 1

2.2 Operating Conditions

Before initial operation and during operation these operating conditions have to be observed to guarantee safe and interference-free service of our printing systems.

Therefore please carefully read these operating conditions.

Shipment and storage of our printing systems are **only** allowed in original packing.

Installation and initial operation of printing system is only allowed if operating conditions were **fulfilled**.

Commissioning is prohibited until it can be established that, where relevant, the machine into which the partly completed machinery is to be incorporated complies with the provisions of Machinery Directive 2006/42/EC.

Initial operation, programming, operation, cleaning and service of our printing systems are only recommended after careful study of our manuals.

Operation of printing system is only allowed by especially trained persons.



NOTICE!

Perform trainings regularly.

These indications are also valid for someone else's equipment supplied by us.

Only use original spare and exchange parts.

Stray radiation and immunity from disturbance

Emitted interference according to EN 61000-6-4: 2007 industrial sector

- Interference voltage to wires according to EN 55032:2015
- Interference field power according to EN 55032:2015
- System perturbation according to EN 61000-3-2:2014
- Flicker according to EN 61000-3-3: 2013

Stray radiation and immunity from disturbance

Immunity to interference according to 61000-6-2: 2005 industrial sector

- Stray radiation against discharge of static electricity according to EN 61000-4-2: 2009
- Electromagnetic fields according to EN 61000-4-3: 2006
- Fast transient burst according to EN 61000-4-4: 2012
- Surge according to EN 61000-4-5: 2014
- High-frequency voltage according to EN 61000-4-6: 2014
- Magnetic field immunity EN 61000-4-8: 2010
- Voltage interruption and voltage drop according to EN 61000-4-11: 2004

**NOTICE!**

This is a machine of type A. This machine can cause interferences in residential areas; in this case it can be required from operator to accomplish appropriate measures and be responsible for it.

Air convection

To avoid inadmissible heating, free air convection has to be ensured.

Limit values

Ambient temperature °C (operation): Min. +5 Max. +35

Ambient temperature °C (storage): Min. -25 Max. +60

Relative air humidity % (operation): Max. 80

Relative air humidity % (storage): Max. 80
(bedewing of printing systems not allowed)

Guarantee

We do not take any responsibility for damage caused by:

- Ignoring our operating conditions and operating manual.
- Incorrect electric installation of environment.
- Building alterations of our printing systems.
- Incorrect programming and operation.
- Not performed data protection.
- Using of not original spare parts and accessories.
- Natural wear and tear.

When (re)installing or programming our printing systems please control the new settings by test running and test printing. Herewith you avoid faulty results, reports and evaluation.

Only specially trained staff is allowed to operate the printing systems.

Control the correct handling of our products and repeat training.

We do not guarantee that all features described in this manual exist in all models. Caused by our efforts to continue further development and improvement, technical data might change without notice.

By further developments or regulations of the country illustrations and examples shown in the manual can be different from the delivered model.

Please pay attention to the information about admissible print media and the notes to the printing system maintenance, in order to avoid damages or premature wear.

We endeavoured to write this manual in an understandable form to give and you as much as possible information. If you have any queries or if you discover errors, please inform us to give us the possibility to correct and improve our manual.

3 Product Description

The applicator APL 100 is an optional device to use with printing systems of ILX series for automatically applying the printed label onto the product.

The labels are transferred with a pad, which moves between the two positions, starting position and labelling position, by a compressed-air driven pneumatic cylinder.

In the starting position, the label is picked up from the printing system.

A sensor at the cylinder signals when the pad is in the starting position.

The label is removed from the carrier ribbon directly at the dispensing edge of the printing system. It is sucked on the pad by a vacuum via drillings at the bottom of the pad.

For support, the label is also blown against the pad (supporting air) with an air current coming from a blow tube.

The correct transfer of the label is controlled by a vacuum sensor.

Next, the pad is moved down into the labelling position. Reaching the labelling position is confirmed by another sensor (labelling position sensor).

In the labelling position the label is transferred onto the product.

The supporting air and the vacuum as well as the speed of the cylinder are adjustable. That way the applicator can be adapted to different label materials and sizes.

The pressure for the cylinder movement is reduced in relation to the operating pressure of the entire labelling machine so that the danger of injury is reduced as much as possible.

To avoid contamination within the vacuum channels they are cleaned by air pressure impulse at the end of each application.

For integration into a superordinated process the printing systems are equipped with 'Dispenser I/O'.

3.1 Apply the Labels

For applying the labels on the products, there are three different possibilities available:

Stamp on

The label is pressed directly onto the product.

Blow on

The pad moves to a pre-adjusted position approximately 10 mm away from the product. The label is blown onto the product by an air stream.

Roll on

In the starting position the label is forwarded until touching the roller of the roll on pad. At the labelling position the roller is pressed onto the product. Then the label is applied and rolled on by the movement of the product.

3.2 Applicator Overview

Front view

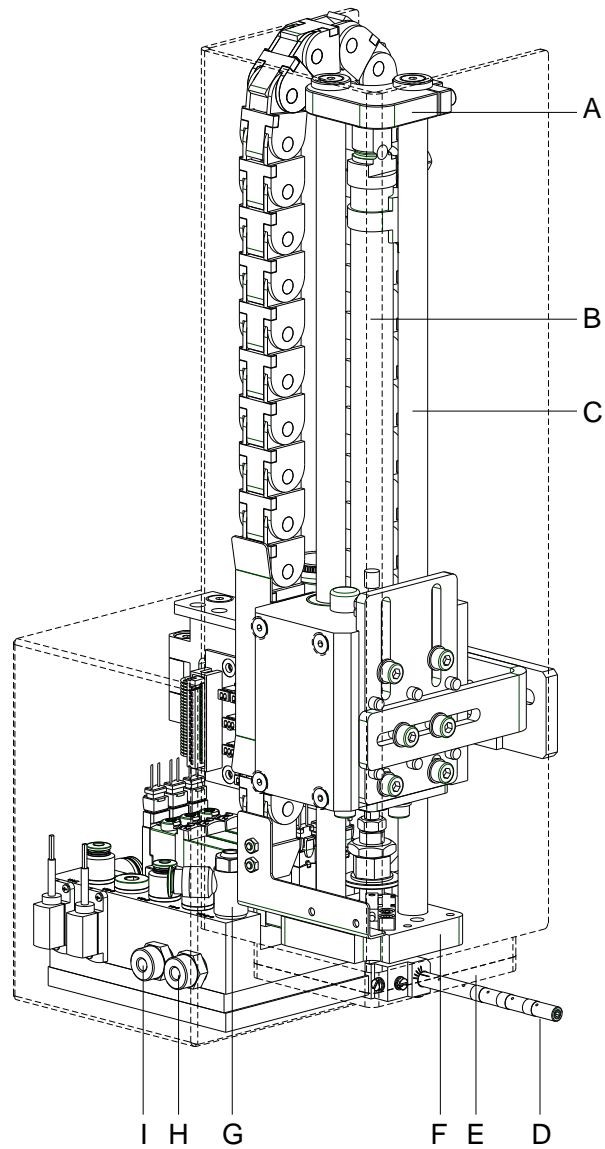

Figure 2

- A = Stopper for the operation mode "blow on"
- B = Pneumatic cylinder
- C = Cylinder unit
- D = Blow tube for supporting air
- E = Pad (application specific)
- F = Pad holder
- G = Throttling back valve 'blowing air'
- H = Throttling back valve 'vacuum'
- I = Throttling back valve 'supporting air'

Rear view

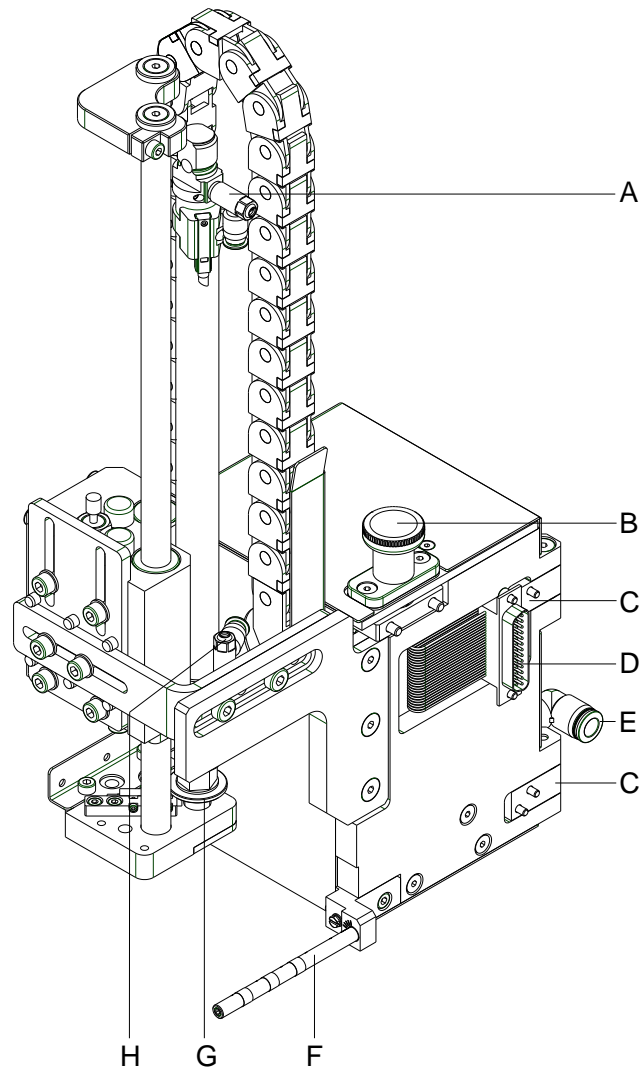

Figure 3

- A = Throttling back valve 'cylinder' (top)
- B = Locking pin with interlock
- C = Hinge for fixing the applicator to the printing system
- D = Interface to the printing system
- E = Compressed air connector
- F = Blow tube for supporting air
- G = Pad holder
- H = Throttling back valve 'cylinder' (bottom)

**Service unit -
right version**

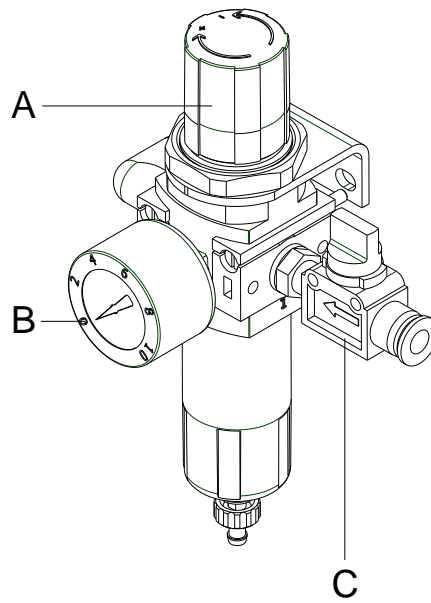

Figure 4

- A = Adjusting knob of pressure control valve with filter
- B = Manometer
- C = Shut-off valve

**Service unit -
left version**

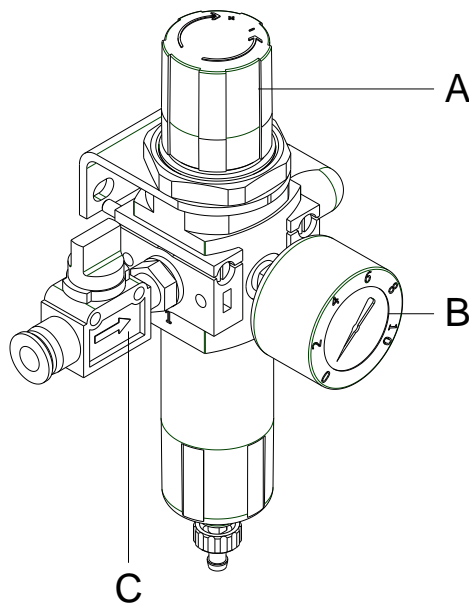

Figure 5

- A = Adjusting knob of pressure control valve with filter
- B = Manometer
- C = Shut-off valve

3.3 Pads

Tamp pad

Universal tamp pad

Standard size:
70 x 85 mm

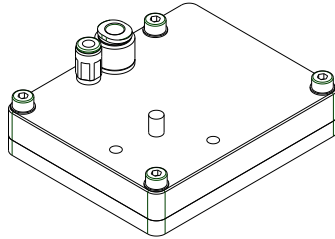

Figure 6

Spring-mounted universal tamp pad

Standard size:
90 x 120 mm

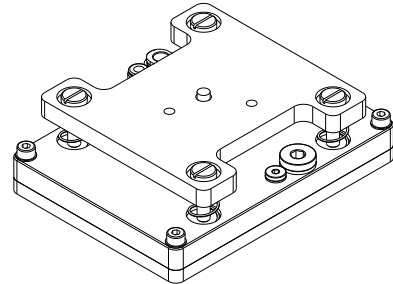

Figure 7

Universal tamp are available in different standard sizes. According to the size of the label the holes may be pierced by the customer. For that purpose a piercing pin is included in the delivery contents.

On request, tamp pads customized to the label sized are delivered.

Roll-on pad

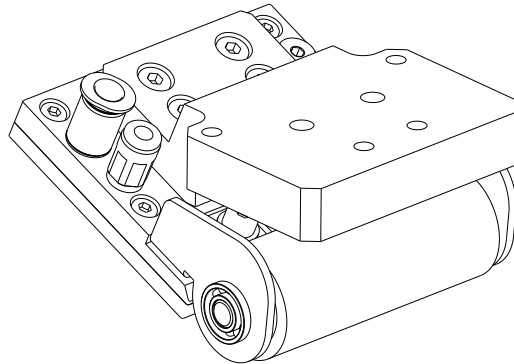

Figure 8

Roll-on pads are only produced on request customized to the label size.

Blow pad (w/o teflon tape)

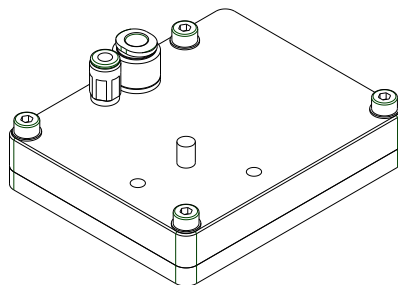

Figure 9

Blow pads are only produced on request customized to the label size.

3.4 Remove the Covers

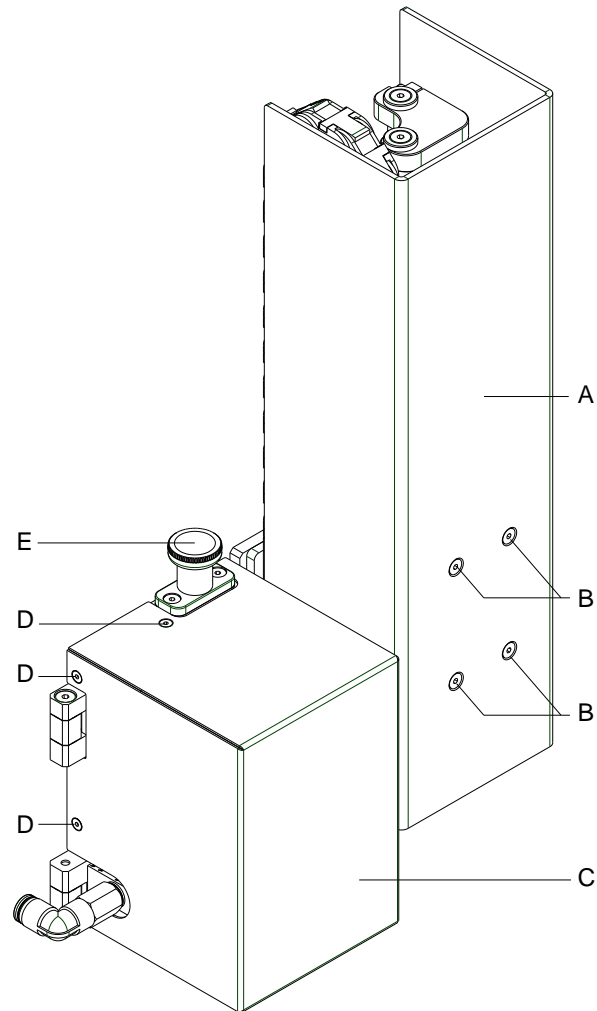

Figure 10

Removing the pneumatic cover

1. Loosen screws (B).
2. Remove the cover (A).

Removing the electronics cover

1. Loosen screws (D).
2. Remove the cover (C).

4 Technical Data

| Label transfer / Operating modes | Stamp on | Blow on | Roll on |
|---------------------------------------|---|---------------|---------------|
| Label width | | | |
| ILX 5X | 20 ... 56 mm | 20 ... 56 mm | 20 ... 56 mm |
| ILX 8X | 20 ... 86 mm | 20 ... 86 mm | 20 ... 86 mm |
| ILX 10X | 20 ... 112 mm | 20 ... 112 mm | 20 ... 112 mm |
| Label height (mm) | 15 ... 210 mm | 15 ... 100 mm | 70 ... 210 mm |
| Label height universal pad | 15 ... 80 mm | 15 ... 80 mm | 70 mm |
| Utilizable cylinder stroke | | | |
| 200 mm cylinder | 170 mm | 170 mm | 200 mm |
| 300 mm cylinder | 270 mm | 270 mm | 300 mm |
| 400 mm cylinder | 370 mm | 370 mm | 400 mm |
| 500 mm cylinder | 470 mm | 470 mm | 500 mm |
| Compressed air pressure | 5 bar | 5 bar | 5 bar |
| Product surface | eben | eben | eben |
| Product height variable | ✓ | - | ✓ |
| Product height fixed | ✓ | ✓ | ✓ |
| Product fixed | ✓ | ✓ | - |
| Product linear movement | - | ✓ | ✓ |
| Labelling from top | ✓ | ✓ | ✓ |
| Labelling from bottom | ✓ | ✓ | ✓ |
| Labelling from the side | ✓ | ✓ | ✓ |
| Retraction depth | 25 mm | - | - |
| Direction | right and left version | | |
| Compressed air control/vacuum control | available | | |
| Service unit | filter regulation with manometer and shut-off valve | | |
| Voltage supply/current supply | by label printing system | | |
| Dimensions (w x h x d) | 237 x 423 x 126 mm | | |
| APX 7020 | 237 x 423 x 126 mm | | |
| APX 7030 | 237 x 523 x 126 mm | | |
| APX 7040 | 237 x 623 x 126 mm | | |
| APX 7050 | 237 x 723 x 126 mm | | |
| Weight | 5 kg* | | |

* measured by APX 7020

5 Installation

5.1 Scope of Delivery



NOTICE!

Please keep the original packaging in case the applicator must be returned.

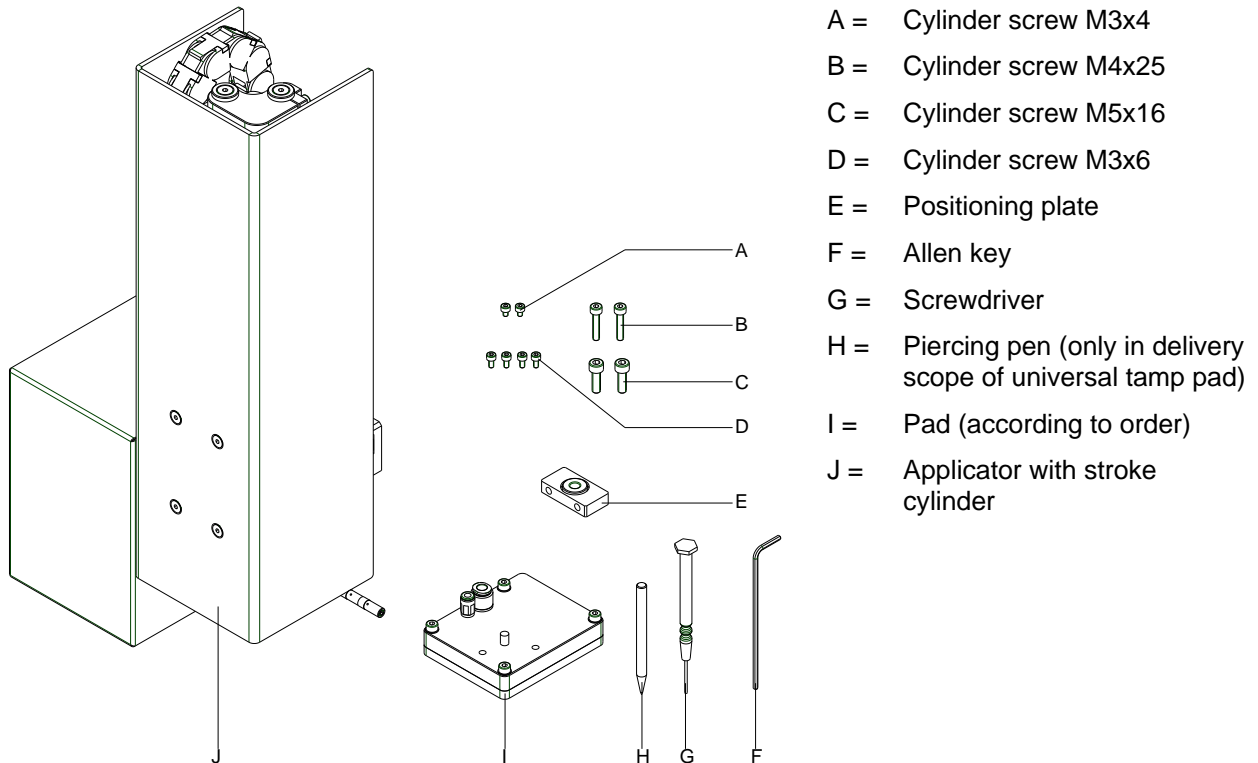

Figure 11



CAUTION!

The printing system and the applicator can be damaged by moisture and water.

⇒ Set up the printing system with applicator only in dry locations protected from splash water.

5.2 Install the Applicator to the Printing System



CAUTION!

Danger of injury by inadvertent move out of the cylinder.

- ⇒ Disconnect the printing system from the power supply before mounting the applicator.
- ⇒ Connect the compressed air only after mounting the applicator to the printing system.

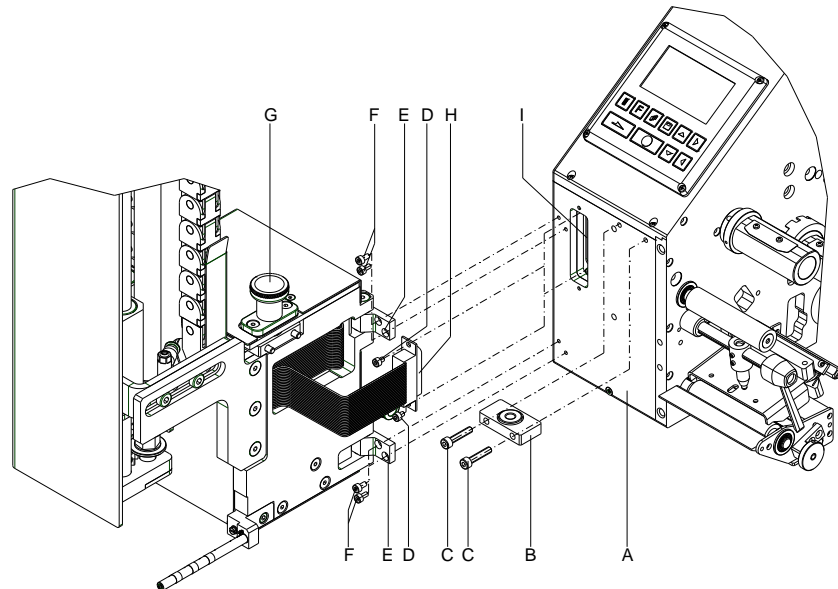

Figure 12

1. Attach the support plate (B) to the front plate (A) of the printing system using screws (C).
2. Attach the hinges (E) of the applicator to the front plate (A) of the printing system using screws (F).
3. Connect the plug (H) of the applicator with the peripheral connection (I) of the printing system and secure with the screws (D).
4. Pivot the applicator and secure with the locking pins (G).

5.3 Pierce the Universal Tamp Pad

On the bottom of the pads there are holes for sucking and holding the labels by vacuum. When an universal tamp pad is delivered these holes are covered by the sliding foil and must be opened according to the label size. For that purpose a piercing pin is included in the contents of delivery.

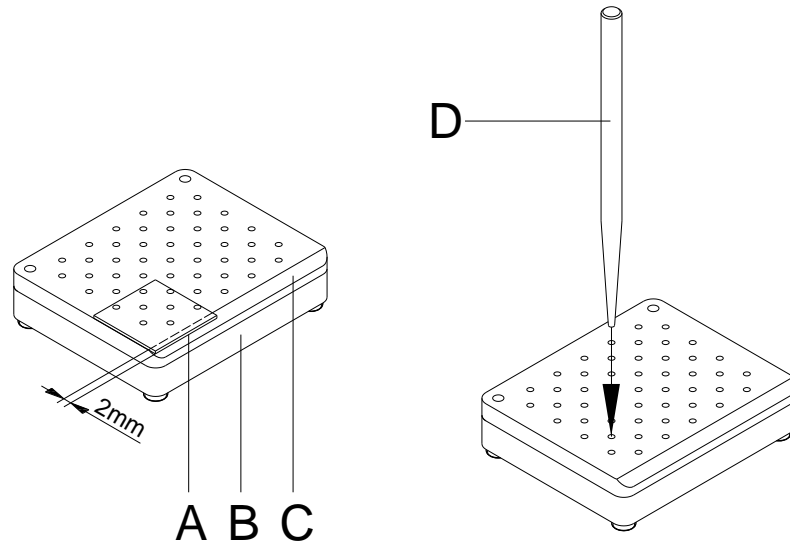

Figure 13

1. Place a label (A) to be operated on the bottom side of the pad (B). Note the position of the slanted edge (C).
2. Align the label to the side edge in such a way that it reaches over the rear edge of the pad by 2 mm.
3. Open all holes, which are certainly covered by the label. Open the holes completely by turning the piercing pin (D) inside the holes.



CAUTION!

Malfunctions by a too weak vacuum.

- ⇒ Do not open holes which are located less than 1 mm from a label edge.

5.4 Prepare for Using a Sprint-Mounted Tamp Pad



NOTICE!

For using a spring-mounted universal tamp pad (90 x 120 mm) the fitting of the cylinder unit must be changed.

The cylinder unit (E) can be mounted on the bracket (A) in multiple different positions.

When the applicator is delivered, the cylinder unit (E) is mounted on the bracket (A) using the upper threaded hole. That position is suitable for the most pads.

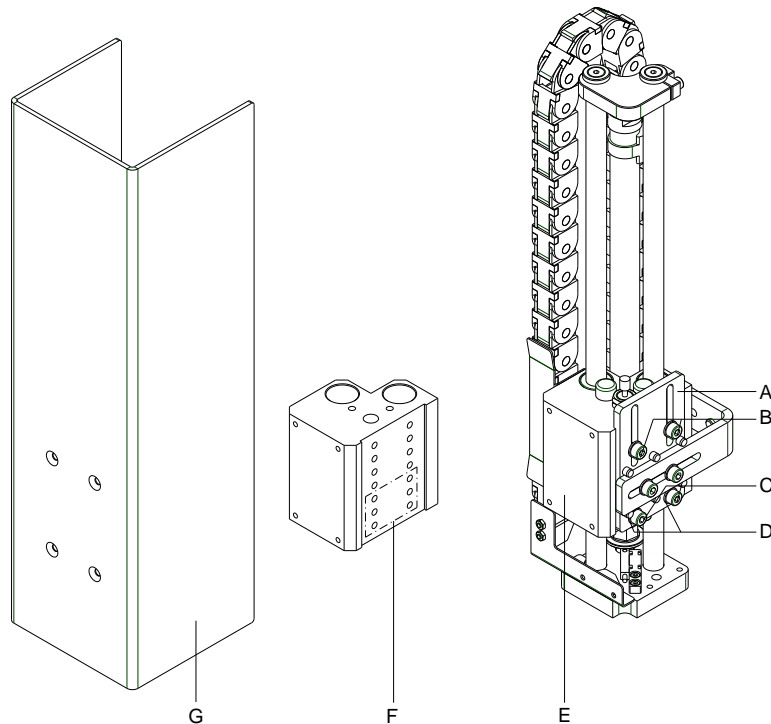

Figure 14

1. Remove the cylinder cover (G).
2. Remove the screws (B+C) and washers (D).
3. Push the cylinder unit (E) on the support plate (A) upwards.
4. Attach the cylinder unit (E) to the support plate (A) at the lower holes (F) using the screws (C) and washers (D).

5.5 Install the Pad

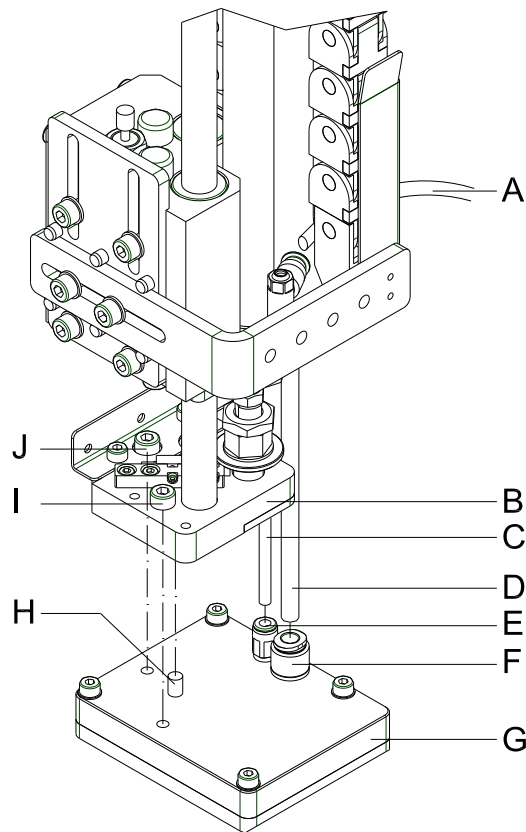

Figure 15

1. Pull the tube (A) out of the push-in-fitting.
2. Insert the pin (H) on the pad (G) into the hole on the bottom side of the guiding plate (B).
3. Fix the pad (G) with the cylinder screws (I, J) at the pad holder (B) and make a rough adjustment of the pad to the dispensing edge of the printing module.
4. Insert the vacuum tube (C) and the blowing air tube (D) into the appropriate push-in-fittings (E, F) of the pad.
5. Insert the tube (A) into the connection of throttling back valve on the cylinder.



CAUTION!

Danger of collision of the pad with other parts of the labelling system.

⇒ Before connecting the applicator to the compressed air supply please roughly align the pad in all directions..

5.6 Install the Connections

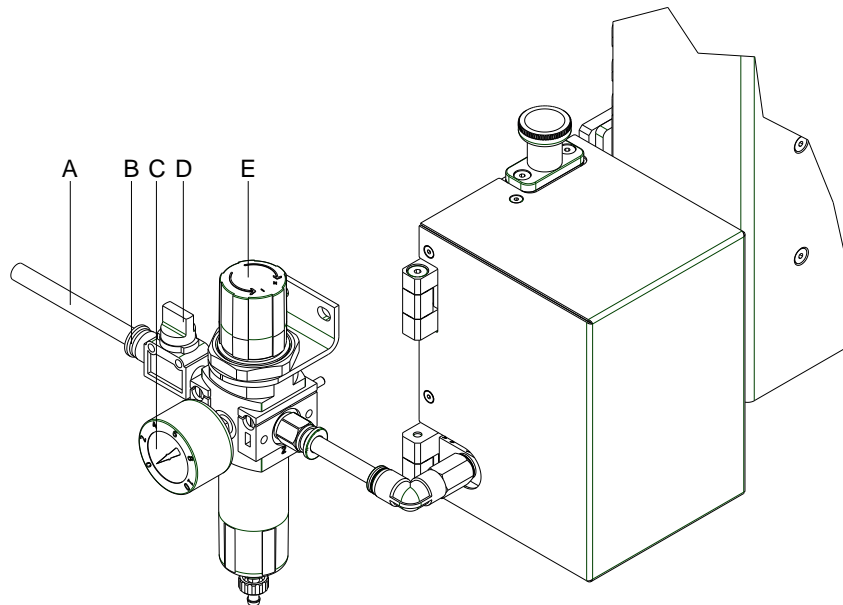

Figure 16

1. Prepare the power supply and interface at the printing system (see operating manual of the printing system).
2. Close the shut-off valve (D / lever at the valve is turned across the air flow direction).
3. Connect the applicator to the compressed air supply.
4. The operating air pressure for the applicator is pre-adjusted to 0.5 MPa (5 bar). Check the pressure at the manometer (C) of service unit. Correct the adjustment if necessary:
 - pull knurled knob (E) up.
 - turn knob to tune required operating pressure of 5 bar.
 - push knob down.
5. Open the shut-off valve (D / lever is turned in the air flow direction).
6. Switch on the printing system at the power switch.



CAUTION!

The pad will immediately be moved in the starting position.
 Danger of crushing to hand and fingers by the moving pad.

- ⇒ Do not reach into the zone of the moving pad.
- ⇒ Keep long hair, loose clothes and jewellery distant from the zone of the moving pad.
- ⇒ Danger of striking by the moving rods.
 Do not reach or bend into the zone of the moving rods.

6 Options

6.1 Quick Apply

The optional "quick apply" function allows reduction of the impact pulse of the pneumatic cylinder.

"Quick apply" is an adjustable pneumatic absorption and/or brake by means of an additional pneumatic valve.

The cylinder is set to the maximum speed. The "quick apply" function decelerates the pad of the applicator just before the application surface of the product. In this way, cycle times are increased without damaging the product.



NOTICE!

The 'Quick Apply' option is only active in the operating modes 'Stamp on' and 'Blow on'.

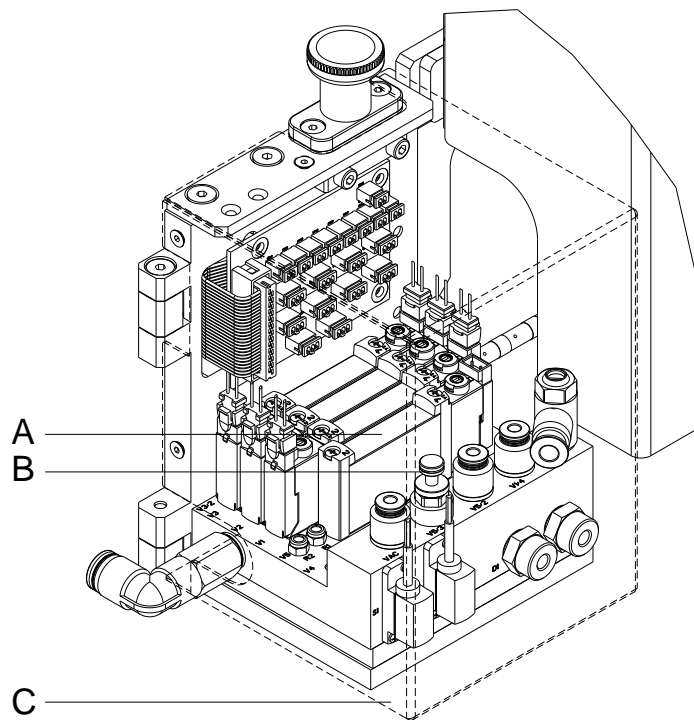

Figure 17

1. Unscrew and remove the protective cover (C) (see chapter 3.4, page 18).
2. Turn the adjusting screw (B) to set the absorption of solenoid valve (A).
3. Attach the protective cover.
4. In the "quick apply" menu of the printing system, set the desired delay in ms for valve activation.

6.2 Shock Absorber

The optional shock absorber allows reduction of the impact pulse of the pneumatic cylinder.

The additionally installed shock absorber absorbs the impact forces of the cylinder and ensures a soft limit position of the pad.

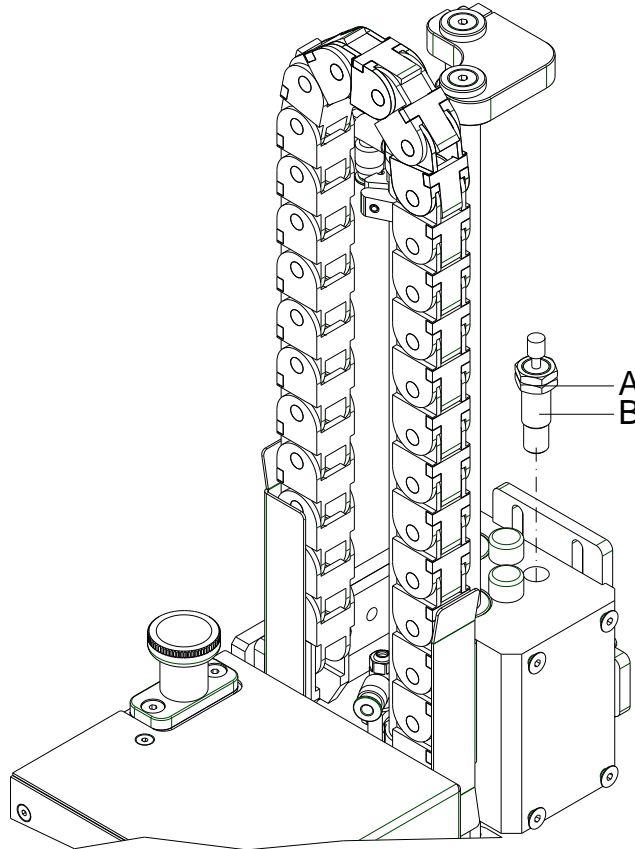

Figure 18

1. Move the shock absorber (B) to the desired height by screwing it in.
2. Secure the position of the shock absorber (B) against unintentional loosening using the counter nut (A).

6.3 Product Sensor

The "product sensor" option is used for optical, contact-free registration of products in order to obtain input signals for the printing system.

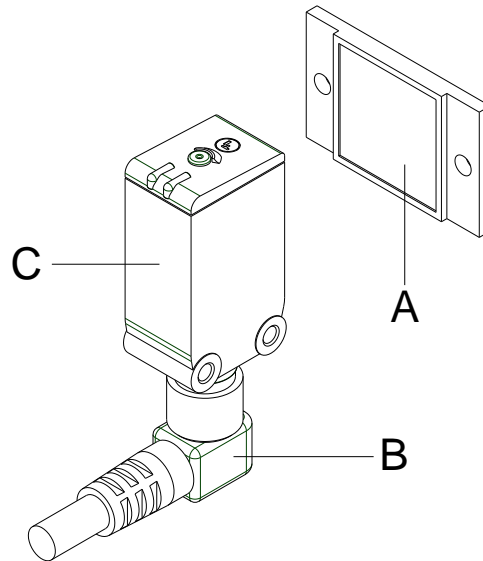

Figure 19

A = Reflector

B = Connecting line

C = Reflexion photocell



NOTICE!

When using reflection photocells you should observe that other light (e.g. working lamp) on the photocell is prevented.

1. Connect the connecting line (B) of the reflection photocell (C) to the I/O 24 interface.
2. Attach the reflector (A) at right angles with the reflection photocell (C).

7 Configuration

The label applicator can be operated in different ways. While the original process stays the same, the operation mode can be chosen within the function menu of the connected printing system.

The most important setting is the selection between the operating modes "stamp on", "blow on" and "roll on". Additionally the applicator has different application modes concerning the order of printing and applying within one labelling cycle.

| | Stamp on | Roll on | Blow on |
|--------------------------------------|----------|---------|---------|
| Print-Apply | ✓ | ✓ | ✓ |
| Apply-Print Waiting position up | ✓ | ✓ | ✓ |
| Apply-Print Waiting position down | | | ✓ |

7.1 Configuration Parameter

| Parameter | Meaning | Selection |
|-------------------|---|------------------------------------|
| Operating mode | Setting of operating mode Default: Stamp on | Stamp on, Blow on, Roll on |
| Mode | Setting of application mode Default: Print-apply | Print-apply Apply-print |
| Vacuum delay On | Setting of switch-on delay Vacuum Default: 0 ms | 0 ... 2500 ms in 10 steps of ms |
| Vacuum delay Off | Setting of switch-off delay Vacuum Default: 500 ms | 0 ... 5000 ms in steps of 10 ms |
| Support delay On | Duration of switch-on delay for supporting air Default: 0 ms | 0 ... 2500 ms in steps of 10 ms |
| Support delay Off | Duration of switch-off delay for supporting air Default: 500 ms | 0 ... 2500 ms in steps of 10 ms |
| Pressure control | Function of compressed-air control Default: On | On Off |
| Vacuum control | Function of vacuum control Default: On | On Off |
| Pressure time | Duration of pressure time Default: 100 ms | 0 ... 5000 ms in steps of 10 ms |
| Blow time | Duration of blow time Default: 100 ms | 0 ... 2500 ms in steps of 10 ms |

| Parameter | Meaning | Selection |
|--|--|---|
| Waiting position | Waiting position of pad with dispensed label for "blow on + Apply-print" Default: Up | Up Down |
| Roll on time | Duration of roll on time Default: 0 ms | 0 ... 5000 ms in steps of 10 ms |
| Cleaning time | Duration of cleaning time Default: 100 ms | 0 ... 2500 ms ins steps of 10 ms |
| Timeout hub | Moving up/down of pad Default: 0 ms | 0 ... 5000 ms in steps of 10 ms |
| Quick-Apply (option for APX 7000) | Duration of switch-on delay of the additional cylinder valve | 0 ... 2500 ms in steps of 10 ms |
| Querachse (not available at APX 7000) | Setting, if a transversal movemen is to be effected before the downwards movement of the pad Default: Off | On Off |
| Labelling signal | Setting, if printing and labelling of the label is to be released separately Default: Off | Off Print position Labelling position |
| Test functions | Hub setting Test run of pad without label | |

7.2 Settings in Printing System Function Menu

Switch on the printing system and the display shows the main menu.

Press the key  to access the function menu.

Press the key  until the menu *Label applicator* is displayed.

Press the key  to select the menu.

Press the key  to move to the next mode.

Operating modes

Stamp on:

The label remains in a fixed position. The label is pressed directly onto the product.

Blow on:

The pad moves to a pre-adjusted position approximately 10 mm away from the product. The label is blown onto the product by an air jet stream. The print and apply cycle performs in a fixed position or in linear movement of the product.

Roll on:

The label is dispensed and moved until touching the roller of the roll on pad. In the labelling position, this roll is pressed onto the product. Then the label is applied and rolled on by the movement of product.

Press the key  to move to the next parameter.

Mode

The applicator can be operated in two different ways concerning the order of printing and labelling within one labelling cycle (see chapter 1, page 39).

Print-Apply:

The print of a label is released by an external start signal. At the same time the vacuum on the pad as well as the supporting air from the blow tube are switched on. If the label is printed and picked up completely from tamp, the supporting air is switched off and the lift cylinder is controlled to move the pad down towards the labelling position. A sensor signals when the labelling position is reached.

Following, the vacuum is switched off and the label is transferred to the product. After applying the label, the lift cylinder is so controlled that the pad is again moved back to the starting position.

Now the labelling cycle is finished.

Apply-Print:

At the beginning of the cyclic operation 'Apply-Print' the first label is printed immediately and passed to the pad.

The pad with the printed label is in starting position and the vacuum at the pad is switched on.

At start of the cyclic operation when sending the start signal, the first label is already on the pad. The following process is similar to the mode 'print-apply' but at the end of the cycle the next label is printed and picked up by the pad.

Now the labelling cycle is finished.

Press the key  to move to the next parameter.

Vacuum delay On

The vacuum is not switched on immediately at print start, but only after the label has been fed for a certain period. This delay causes the label to run under the pad more easily, as it is not immediately sucked in and thereby slowed down.

Value range: 0 ... 2500 ms

Step size: 10 ms

Default: 0 ms

Press the key  to move to the next parameter.

Vacuum delay Off

The vacuum is not switched off immediately when the lower end position is reached, but only after the label has been pressed for a certain period. This delay ensures that the label does not move underneath the pad during stamping.

Value range: 0 ... 5000 ms

Step size: 10 ms

Default: 0 ms

Press the key  to move to the next parameter.

Support delay On

The supporting air from the blow tube is not immediately switched on at print start but only if the label has covered a distance. This delay helps to prevent a turning or swinging at the front of the label and consequently avoids faults when the label is being picked up from printing system.

Value range: 0 ... 2500 ms

Step size: 0 ms

Default: 0 ms

Press the key  to move to the next parameter.

Support delay Off







Delayed to the process of the label being picked up, the supporting air is switched off.





In many cases, after being picked up by the pad the label edge may still stick on the liner. This may affect the accuracy of the label positioning or even cause faults in the labelling. Therefore, switching off the air blow delayed can be useful to separate the label from liner and neatly place the label on the surface of pad.

Value range: 0 ... 2500 ms

Step size: 10 ms

Default: 500 ms

- Press the key  to move to the next parameter.
- Pressure control**
- With activated compressed air control, with help from a compressed air sensor it is checked at each labelling cycle if the compressed air fits with the valve block. If no compressed air is presented, the labelling cycle is stopped and the error message 'compressed air' is displayed.
- If the parameter 'pressure control' is set to Off, the error treatment as described above will not be effected. This can be especially helpful for the initial operation of the labelling system.
- For standard operation, set the parameter to On.
- Press the key  to move to the next parameter.
- Vacuum control**
- The label transfer from printing system to applicator is controlled by a vacuum sensor. If the transfer of label fails, the sucking holes on the pad will not be covered by the label and therefore no vacuum can originate on the pad. Afterwards an error message appears and the label strip will be fed back.
- If the parameter 'vacuum control' is set to Off, the error treatment as described above will not be effected. This can be especially helpful during adjustments, because the immediate backfeed will be cancelled and therefore it is easier to check the reasons for the faulty transfer.
- For standard operation, set the parameter to On.
- Press the key  to move to the next parameter.
- Pressure time**
- This parameter is only active if the operating mode "stamp on" is selected. The time period can be adjusted while the pad is kept in the labelling position for applying the label onto the goods.
- Press the key  to move to the next parameter.
- Blow time**
- This parameter is only active if the operating mode "blow on" is selected. The time period can be adjusted, while the blowing air is switched on for transferring the label onto product.
- Value range: 0 to 2500 ms
Step size: 10 ms
Default: 100 ms
- Press the key  to move to the next parameter.
- Waiting position**
-  **NOTICE**
- This parameter is only active if the operating mode "blow on" and mode 'apply-print' are selected.
- Waiting position up:**
- In cyclic mode the pad with the printed label waits in the labelling position near the dispensing edge of printing system for the external start signal.
- Waiting position down:**
- In cyclic mode the printed label is transported to the labelling position at the end of a cycle.
- So the next cycle begin with blowing up the label.

- Press the key  to move to the next parameter.
- Roll on time**
- This parameter is only active if the operating mode "blow on" is selected. The time period can be adjusted while the roll on pad is stopped in labelling position.
- Value range: 0 ... 5000 ms
Step size: 10 ms
Default: 0 ms
- Press the key  to move to the next parameter.
- Cleaning time**
- This parameter is only active if the operating mode "blow on" and "roll on" are selected. The time period can be adjusted for the cleaning period of pad after application procedure.
- Value range: 0 ... 2500 ms
Step size: 10 ms
Default: 100 ms (No error message is triggered and the printing system waits until the pad has achieved the corresponding limit position)
- Press the key  to move to the next parameter.
- Stroke timeout**
- Moving up and down of pad.
If the pad does not reach the corresponding final position within the set time, then an error message appears ('final position above' at moving up and/or 'final position below' at moving down).
- Value range: 0 ... 5000 ms
Step size: 10 ms
Default: 0 ms
- Press the key  to move to the next parameter.
- Delay lower end position**
- The reaching of the lower end position within the labelling cycle is not checked immediately after the start of the downward movement, but only when the pad has moved downwards for a certain time. This ignores an erroneous release of the lower end position (e.g. by inertia of the pad).
- Value range: 0 ... 1000 ms
Step size: 10 ms
Default: 0 ms
- Press the key  to move to the next parameter.
- Quick-Apply delay**
- Only with available option quick-apply:**
With this function, the travel speed of the cylinder may be reduced before it hits the product. The time until the delay commences may be set. The exhaust throttle (bottom) on the cylinder must be opened completely for this (see page 27).
- Value range: 0 ... 2500 ms
Step size: 10 ms
Default: 0 ms

Press the key  to move to the next parameter.

Transverse axis

Only with available option transverse axis:

This function allows you to set if the pad makes a transversal movement before the upwards movement, and/or accordingly after the upwards movement back into the print position.

If the parameter 'transverse axis' is set to On, in each case a transverse movement takes place. At setting Off, no transversal movement takes place and the application procedure begins in the print position.

Press the key  to move to the next parameter.

Labelling signal

If printing and applying of the label are to separately released, a separate signal for applying the label can be activated (port 4, start applying).

Off:

No labelling signal is used, i.e. after printing the label and takeover onto the pad, the applying procedure begins immediately.

Print position:

After printing the label and takeover onto the pad, the printer waits in print position for the labelling signal.

Labelling position:

After printing the label and takeover onto the pad, the pad makes a transversal movement into the labelling position. There the printer waits for the labelling signal. With applicators without transversal axis, this setting is identical with the setting 'print position'.

Press the key  to move to the next parameter.

Test functions





Stroke adjust

The arrester can be adjusted and the stroke speed can be set. The pad makes a stroke movement and return again to the basic position after reaching the lower end position.

Press the key  to start the stroke movement.

Press the key  to move to the next parameter.

Input/Output

This menu serves for the applicator setup as well as for error tracing. Input signals of the applicator can be monitored and output signals can be set or reset separately. Press the keys  and  to select the corresponding output for set/reset the output signals. Press the keys  and  to set/reset the corresponding output.

Input signals

- I₁ = Pre-dispense key
 - 1 = key pressed
 - 0 = key not pressed
- I₂ = Final position up
 - 1 = pad in final position up
 - 0 = pad not in final position up
- I₃ = Final position down
 - 1 = pad in final position down
 - 0 = pad not in final position down
- I₄ = Compressed air
 - 1 = compressed air available
 - 0 = no compressed air available
- I₅ = Vacuum
 - 1 = vacuum at pad available
 - 0 = no vacuum at pad available
- I₆ = Final position right
 - 1 = pad in final position right
 - 0 = pad not in final position right
- I₇ = Final position left
 - 1 = pad in final position left
 - 0 = pad not in final position left

Output signal

- O₁ = Move pad downwards
 - 1 = On / 0 = Off
- O₂ = Move pad upwards
 - 1 = On / 0 = Off
- O₃ = Transverse right
 - 1 = On / 0 = Off
- O₄ = Transverse left
 - 1 = On / 0 = Off
- O₅ = Blowing air
 - 1 = On / 0 = Off
- O₆ = Supporting air
 - 1 = On / 0 = Off
- O₇ = Vacuum
 - 1 = On / 0 = Off

8 Signal Diagrams

8.1 Print – Apply (w/o transverse axis)

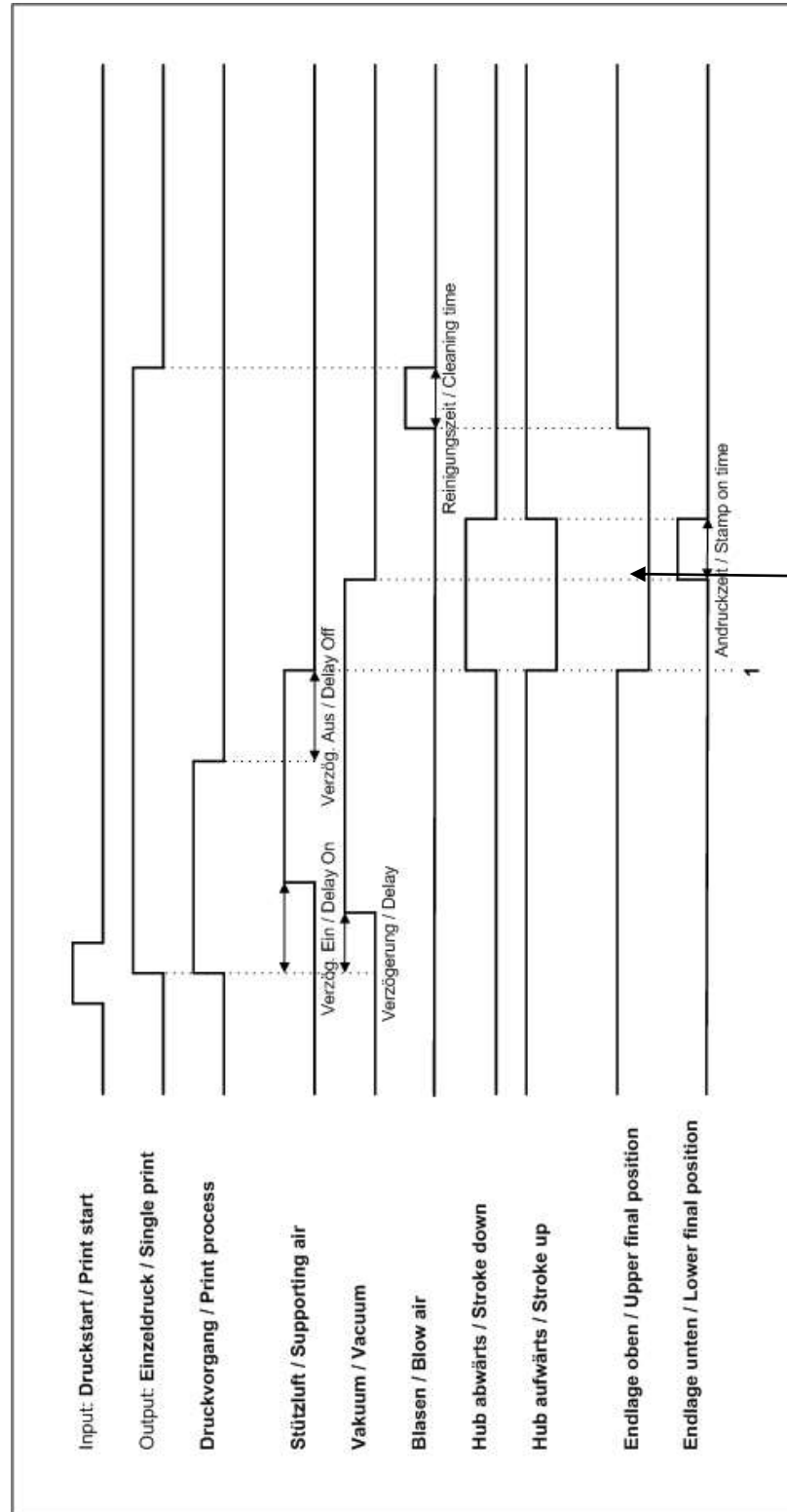

At labelling signal = print position/labelling position, the printer waits here in the print position (identical with the labelling position) for the signal 'applying start' before the label is applied.

Figure 20

8.2 Apply – Print (w/o transverse axis)

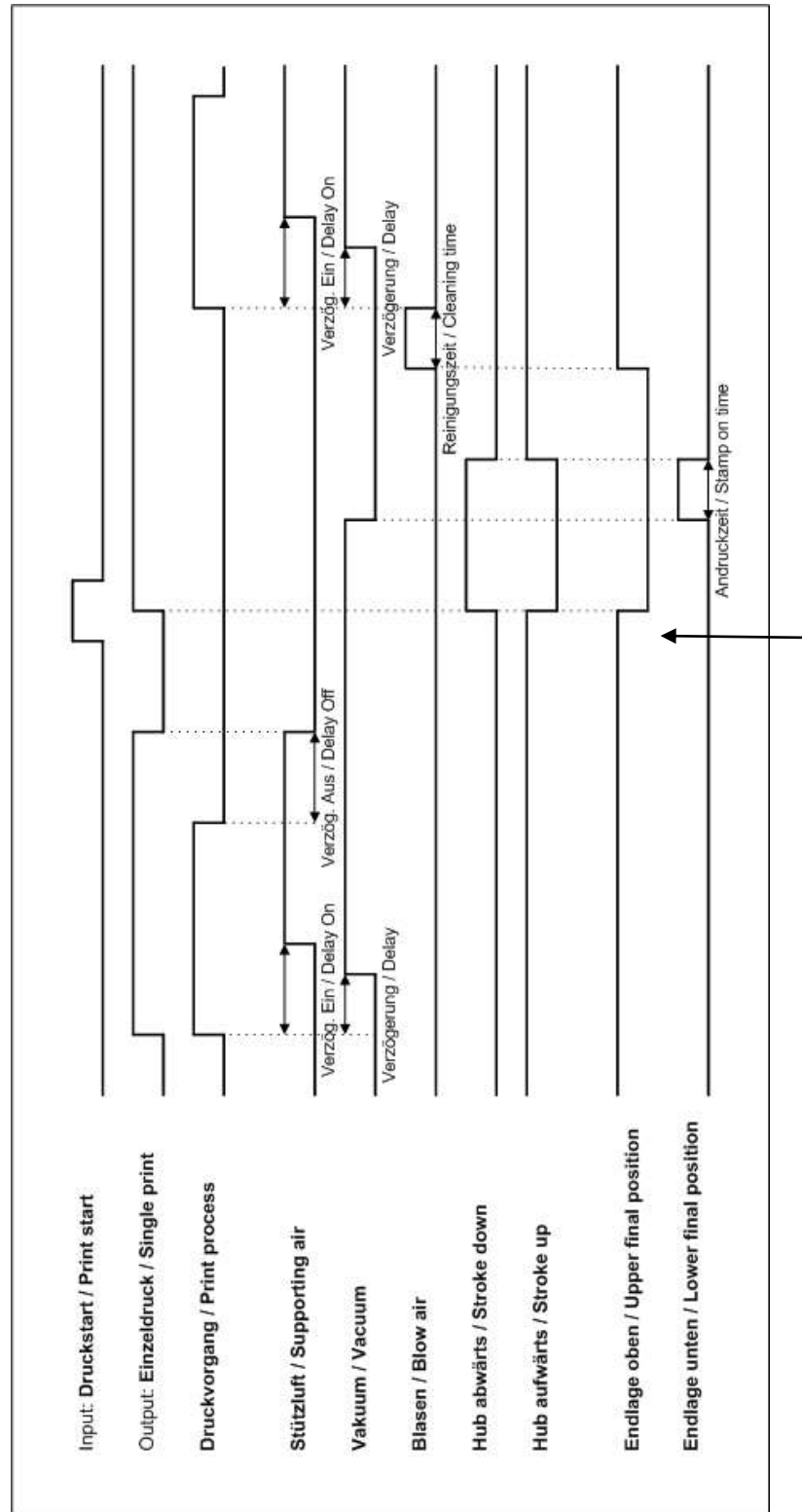

At labelling signal = print position/labelling position, the printer waits here in the print position (identical with the labelling position) for the signal 'applying start' before the label is applied.

Figure 21

9 Mechanical Adjustments



NOTICE!

Before starting with the mechanical adjustments, remove the plexiglass cover (A) by loosening four screws.

Perform the mechanical adjustments in two steps

- ⇒ Roughly align the pad in all directions to avoid collisions of the pad with other parts when switching on the compressed air.
- ⇒ Perform the fine adjustment with compressed air switched on to optimize the labelling process.

9.1 Align the Pad

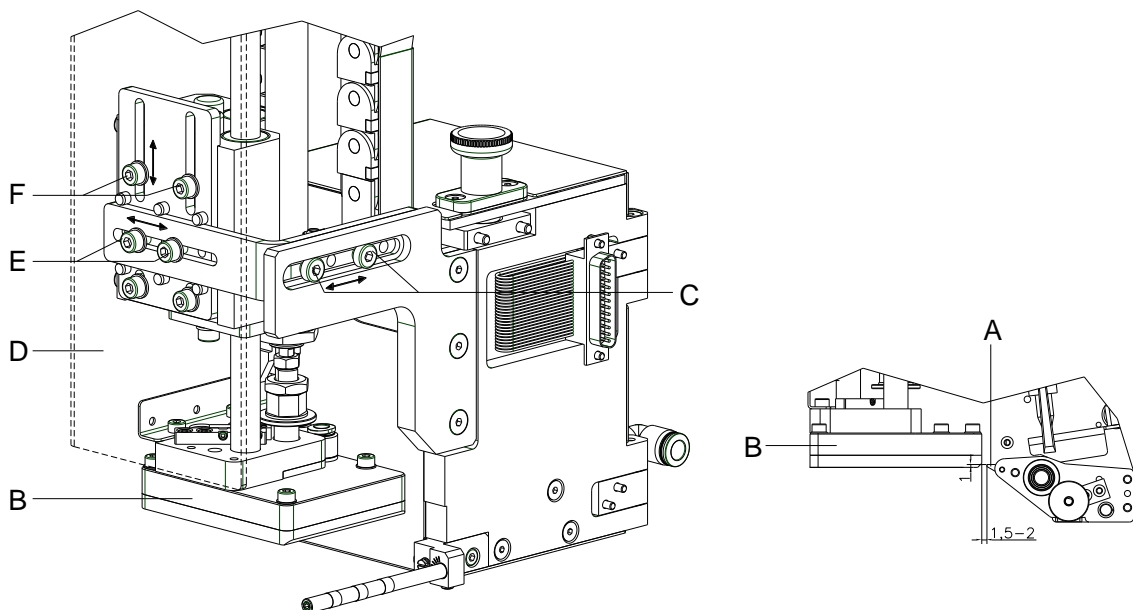

Figure 22

Adjustment in print direction

1. Loosen the screw (E).
2. Shift the cylinder unit including the pad (B) inside the elongated hole in such a way, that the distance between the pad and the dispensing edge (A) is about 2 mm.
3. Tighten the screw (E).

Height adjustment

1. Loosen the screw (F).
2. Shift the cylinder including the pad (B) inside the elongated hole in such a way that the lower rear edge of the pad (4) is located about 1 mm below the dispensing edge (A) of the printing system.
3. Tighten the screw (F).

Side adjustment

1. Loosen the screw (C).
2. Shift the cylinder unit including the pad (B) inside the elongated hole in such a way, that the dispensed label is aligned centrally to the pad respectively to the open holes in an universal pad.
3. Tighten the screw (C).

**NOTICE!**

Check the adjustment with switchen compressed air.

9.2 Adjust the Parallelism between Pad and Dispensing Edge

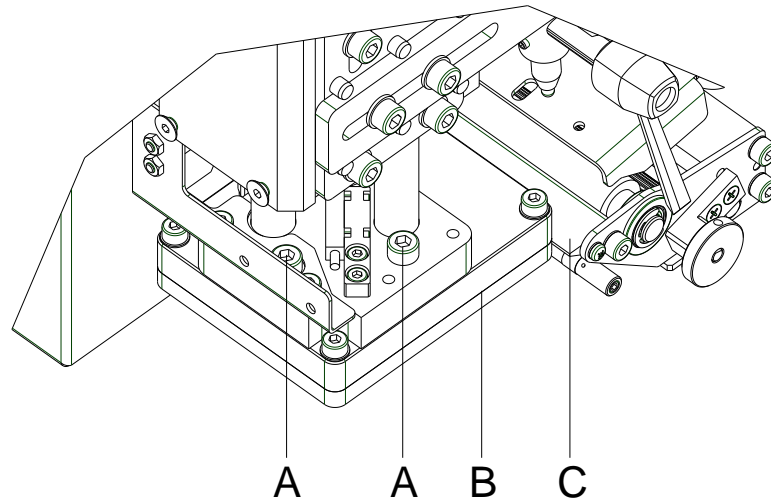

Figure 23

1. Loosen the screw (A).
2. Adjust the parallelism between the rear edge of the pad (B) and the dispensing edge (C) by turning the pad.
3. Tighten the screw (A).

9.3 Open the Holes on the Blow Tube

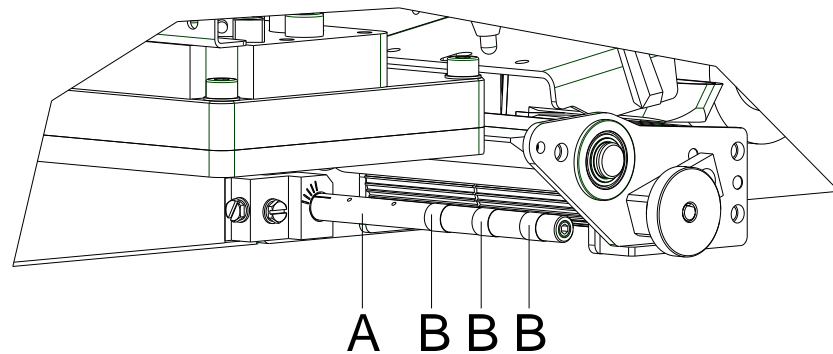

Figure 24

1. The blow tube (A) has holes for the supporting air in regular distances of 14 mm.
2. When the applicator is delivered only the two inner holes are open. The other holes are closed by plastic rings (B).
3. To adjust the supporting air to the label width, the plastic rings (B) can be removed from the holes.
4. Open all holes, which affect certainly the area of the label.

9.4 Align the Blow Tube

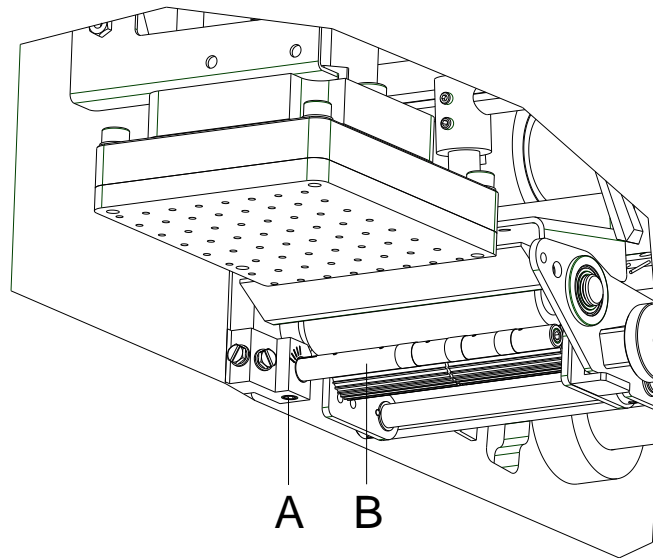

Figure 25

The blow tube (B) for the supporting air can be rotated around its axis. That way the direction of the supporting air can be optimized.

1. Loosen the screw (A).
2. Turn the blow tube (B) in the direction that the air current supports the sucking of the label by the pad.

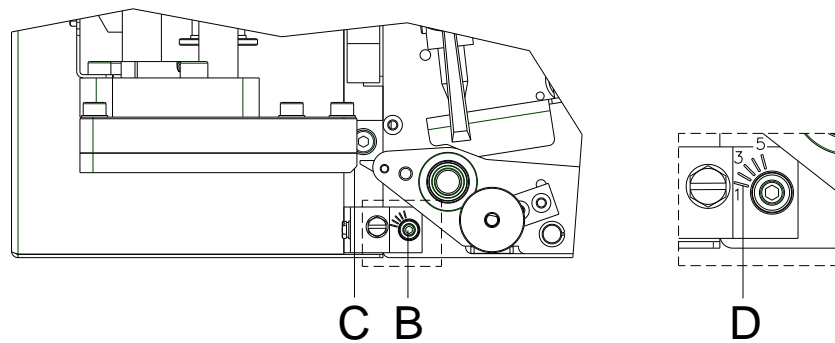

Figure 26

3. For small labels direct the air current to the dispensing edge (C) of the printing system (setting 3 or 4 at the scale (D)).
4. For larger labels direct the air current away from the dispensing edge (C / setting 1).
5. Tighten the screw (A).

9.5 Adjust the Stopper



NOTICE!

The description for adjusting the stopper is only relevant for the "blow on" operating mode.

The stopper is not required in the operating modes "stamp on" and "roll on". It may not limit the pad movement (see next page).

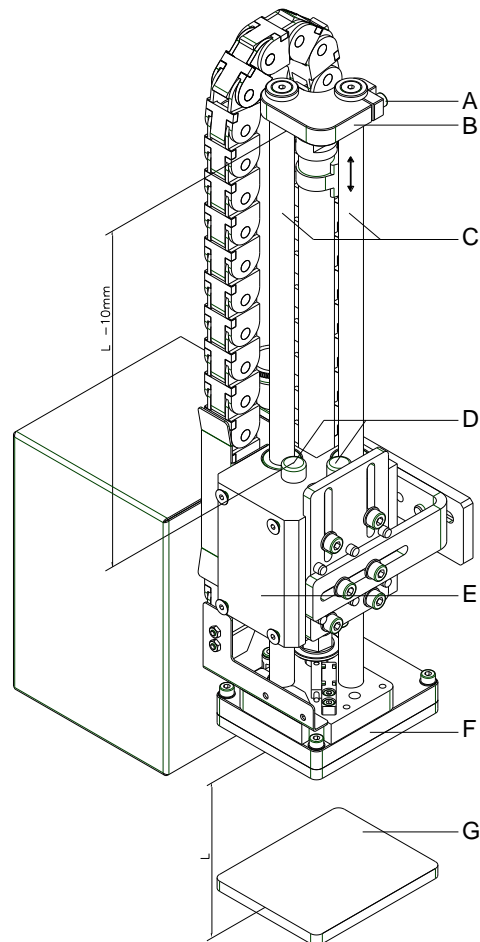

Figure 27



CAUTION!

Danger of injury by inadvertent move out of the cylinder.

⇒ Switch off the printing system and close the shutoff valve for the compressed air at the service unit.

**NOTICE!**

When delivered, a stopper (B) is attached to the guiding rods (C).

**Operating mode
Blow on**

In the "*blow on*" operating mode, the stopper is used to limit the downward movement of the pad in order to set a fixed labelling position.

1. Place sample (G) of the product to be labelled at the labelling position.
2. Measure the distance between the pad bottom edge (F) and the product top edge (G) (distance = L).
3. Loosen the cylinder screw (A) in the stopper (B).
4. Push the stopper (B) against the housing (E) and set a distance between the underside of the stopper (B) and the rubber buffer (D) of L-10 mm.
5. Push the stopper (B) against the housing (E) and tighten the cylinder screw (A).

**Operating modes
Stamp on and
Roll on**

The stopper is not required in the operating modes "*stamp on*" and "*roll on*". The stopper may not limit the pad movement.

1. Loosen the screw (A) in the stopper (B).
2. Push the stopper (B) upwards as far as possible and tighten the screw (A).

10 Pneumatic Adjustments

10.1 Control Valves

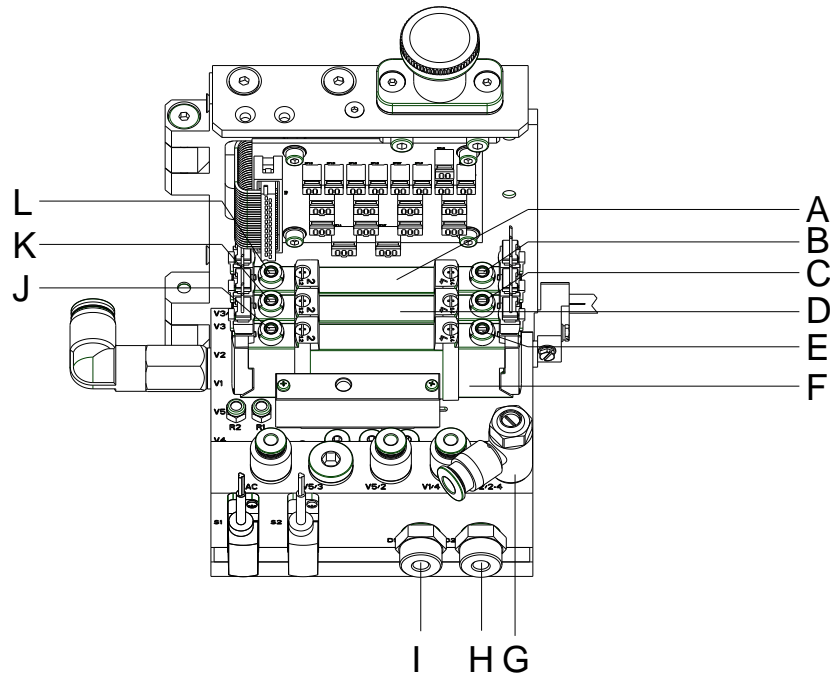

Figure 28

For adjustments of certain applicator functions, release the control valves in the pneumatic system.

- ⇒ Loosen the screws and remove the cover of the pneumatic unit.
- ⇒ The compressed air control valves can be controlled manually with the integrated switch.

3-way valve (F) to control the lift cylinder

If the printing system is switched on the valve will be controlled by electronics and the tamp will hold in the upper end position (home position). If the valve is switched the tamp will move in the lower end position (labelling position).

In normal labelling operation the movement back in the upper end position will start by a signal from the labelling sensor.



NOTICE!

The switching by hand of this valve has only a result in case of a switched off printing system.

Switching the valve by hand over switch (E) the tamp will move down up to the lowest possible position because no control is made by the sensor.

Switching the valve by hand over switch (J) the tamp will move up.

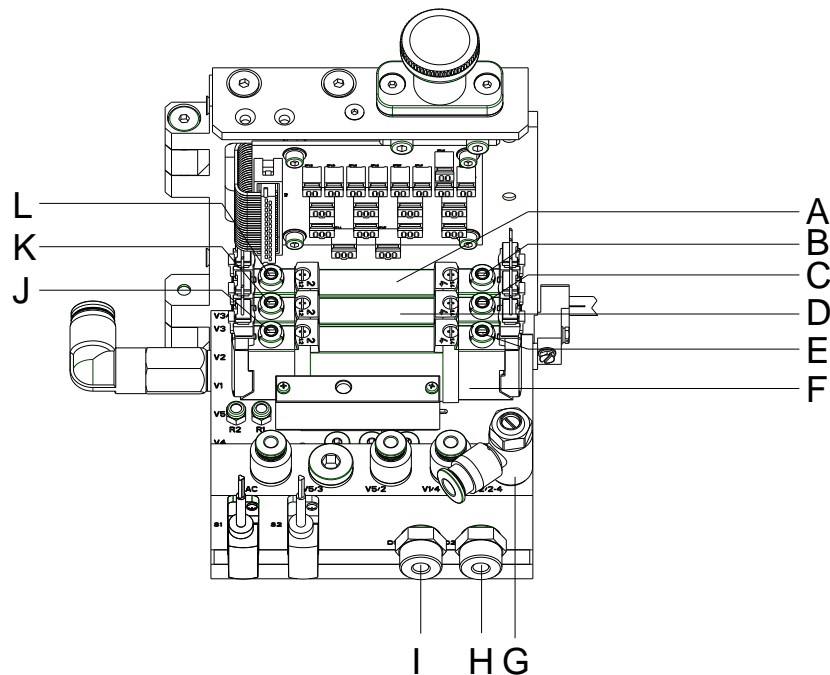

Figure 29

**Double 2-way valve (D)
for blow air**

In the operation mode "blow on" the label will blow up to the product.

In the operating modes "stamp on" and "roll on" the blow air is switched on for a short time after each application to avoid contaminations within the vacuum channels.

For all described functions both valves will be controlled parallel.

By pressing the switch (C or K), the blowing air is only switched on by one of both internal valves. The blowing air can be set with a throttling back valve (G, see chapter 10.3).

**Double 2-way valve (A)
for vacuum /
supporting air**

The two internal valves serve the vacuum nozzle for connecting an in this way for creating the negative pressure at the tamp and independent of this for connecting the support air at the blow tube for the label transfer.

By pressing the switch (B) the vacuum is switched on. The vacuum can be set with the throttling back valve (H, see chapter 10.3).

By pressing the switch (L) the supporting air is switched on. The supporting air can be set with the throttling back valve (I, see chapter 10.3).

10.2 Adjust the Pad Movement Speed

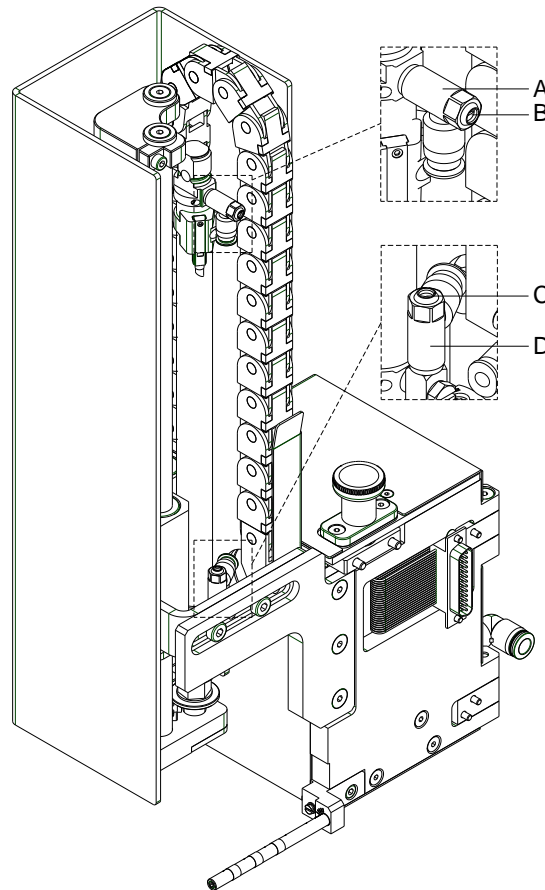

Figure 30

The adjustment of pad movement speed can be regulated with two throttle valves (A, D).

- ⇒ Adjust the pad movement speed as necessary.
- ⇒ To increase the downward speed turn the screw (C) at the lower valve (D) anticlockwise.
- ⇒ To increase the upward speed turn the screw (B) at the upper valve (A) anticlockwise.



NOTICE!

The application pressure of the pad is mainly dependent on the downward speed of the pad.

- ⇒ To reduce the application pressure turn screw (C) in clockwise direction.



CAUTION!

A too high decrease of the downward speed leads to an error message (Error 101 - Lower position).

- ⇒ The downward movement may not need more time as specified in the menu *Timeout Hub* (see page 36).

10.3 Adjust the Vacuum and Supporting Air

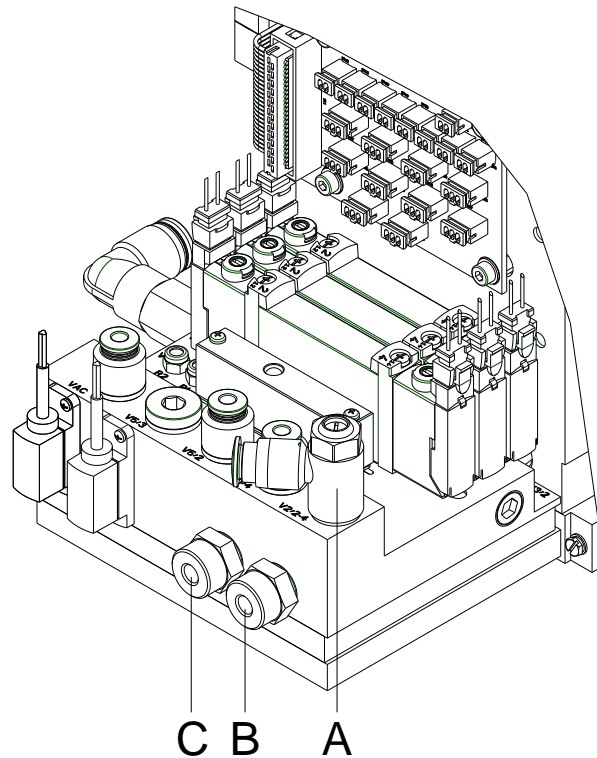

Figure 31

Adjust the supporting air

With the valve (C) the supporting air for blowing the label to the pad can be varied.

- ⇒ Adjust the supporting air in such way that the label is blown on the pad without swirling.
- ⇒ To increase the supporting air turn the screw at the valve (C) anticlockwise.
- ⇒ If necessary adjust the direction of the air current (see chapter 9.4, page 44).

Adjust the vacuum



NOTICE!

With the vacuum setting the final position of the label on the pad can be adjusted. If the vacuum is too high the label feeding may early be stopped.

With the valve (B) the vacuum for sucking the label to the pad can be varied.

- ⇒ Adjust the vacuum in such way that the label is correctly sucked.
- ⇒ To increase the vacuum turn the screw at the valve (B) anticlockwise.

Adjusting the blowing air

With the valve (A) the blowing air for blowing off the label from pad can be varied.

- ⇒ Adjust the blowing air in such way that the label is safely blown off and adheres to the product.
- ⇒ To increase the blowing air turn the screw at the valve (A) anticlockwise.

11 Operation

11.1 Load Labels and Transfer Ribbon



NOTICE!

In dispensing mode the labels are removed after printing, and only the liner is wound up internally.
For detailed information about inserting the material please read the operating manual of the printing system.

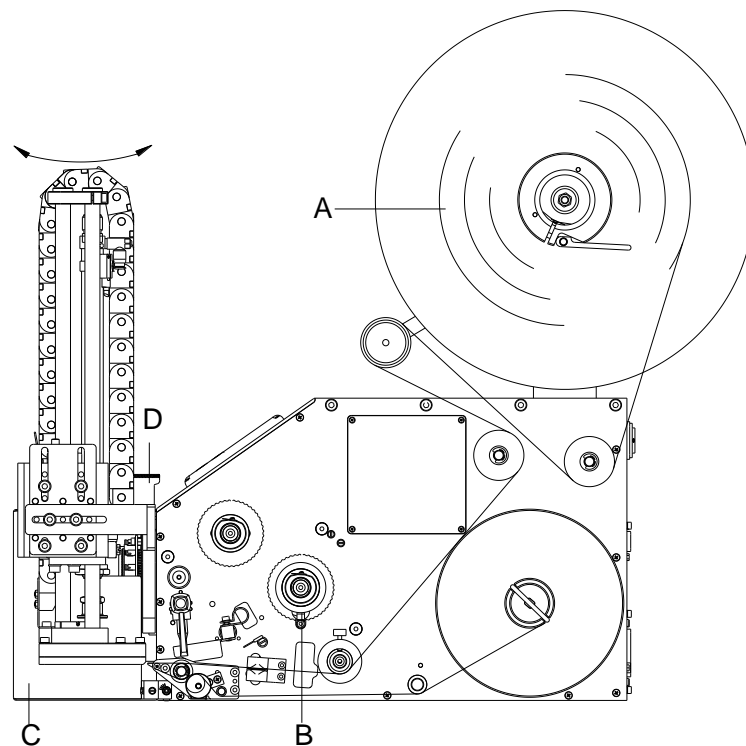

Figure 32



NOTICE!

For better accessibility, the applicator must be pivoted before inserting the labels and the transfer ribbon.

1. Pull the locking pin (D) upwards and rotate it by 90°.
2. Insert the transfer ribbon (B) in the printing system.
3. Insert the label material (A) in the printing system.
4. Close the applicator.



CAUTION!

Collision between the pad and the locking system during the labelling procedure.

⇒ Swivel the locking system on the rewind assistant roller.

11.2 Set the Dispenser Mode



NOTICE!

To operate the printing system in dispenser mode a print order must be started and the printing system is to be in 'waiting' mode.

Switch on the printing system and the display shows the main menu.

Press the key  to access the function menu.

Press the key  until the menu *Dispenser I/O* is displayed.

Press the key  to select the menu.

In the upper line of display, the operating mode can be selected.

In the line below, the dispenser I/O offset (approx. 18 mm) can be set.

Press the key  to move to the next operating mode.

Operating modes

Off:

It is printed without the labels are dispensed.

I/O static:

The input signal evaluated, i.e. it is printed as long as the signal exists. The number of labels which was entered at the print start is printed.

The set dispenser offset is not taken into consideration.

I/O static continuous:

For description of this operating mode, see I/O static.

Continuous means that it is printed as long as new data is transferred via interface

The set dispenser offset is not taken into consideration.

I/O dynamic:

The external signal is evaluated dynamically, i.e. is the printing system in 'waiting' mode a single label is printed at each signal changing.

After the print the set dispenser offset is executed, i.e. a backfeed is effected.

I/O dynamic continuous:

For description of this operating mode, see I/O dynamic.

Continuous means that it is printed as long as new data is transferred via interface.

Photocell:

The printing system is controlled via photocell. The printing system prints automatically a label if the user takes away the label at the dispensing ledge. The print order is finished when the target number of labels is reached.

Photocell continuous:

For description of this operating mode, see Photocell.

Continuous means that it is printed as long as new data is transferred via interface.

11.3 Standard Operation

1. Check all external connections (see chapter 0, page 26).
2. Load the transfer ribbon and the label material (see chapter 11.1, page 53).

**NOTICE!**

Ensure that the locking system (4, Figure 32) is closed.

3. Open the shutoff valve.

**CAUTION!**

If the pad is covered the vacuum sensor may be calibrated faultily.

⇒ Before switching on the printing system-aplicator system ensure that the pad is not covered.

4. Switch on the printing system.

**CAUTION!**

The pad will immediately be moved in the starting position.

⇒ Do not reach into the zone of the moving pad.

⇒ Keep long hair, loose clothes and jewellery distant.

⇒ Do not reach or bend into the zone of the moving rods.

5. Press the key  at the printing system.
A synchronization feed is released. The processed labels have to be removed manually. After a few seconds the printing system carries out a short backfeed to position the front edge of the next label at the printing line.

**NOTICE!**

This synchronizing also has to be carried out when the print job has been interrupted with the key .

Synchronizing is not necessary when the printhead was not lifted between print jobs. This also applies if the printing system was powered off between print jobs.

6. Start a print job.

12 Applicator Interface

Valves may be controlled and limit position sensors may be prompted via different control inputs and outputs.

The control inputs and outputs are made available via a D-sub bushing (25 pins, female) on the front plate of the printing system and are NOT GALVANICALLY ISOLATED.

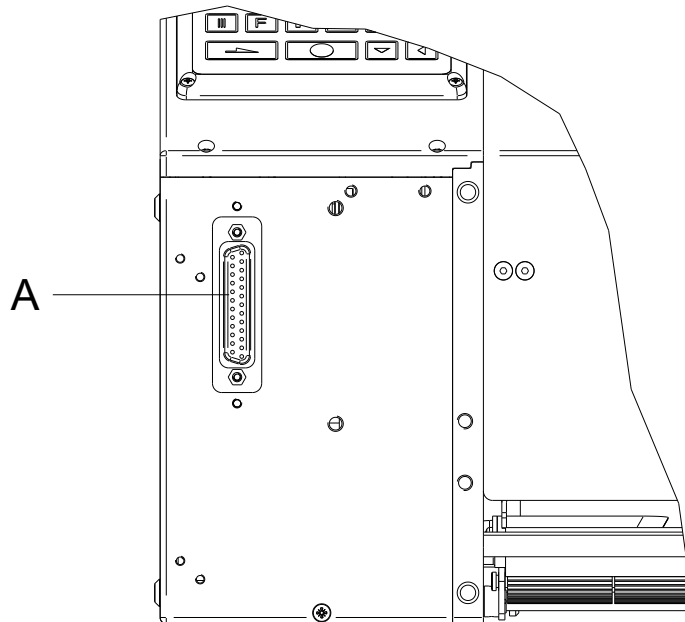

Figure 33

12.1 Printer internal circuitry

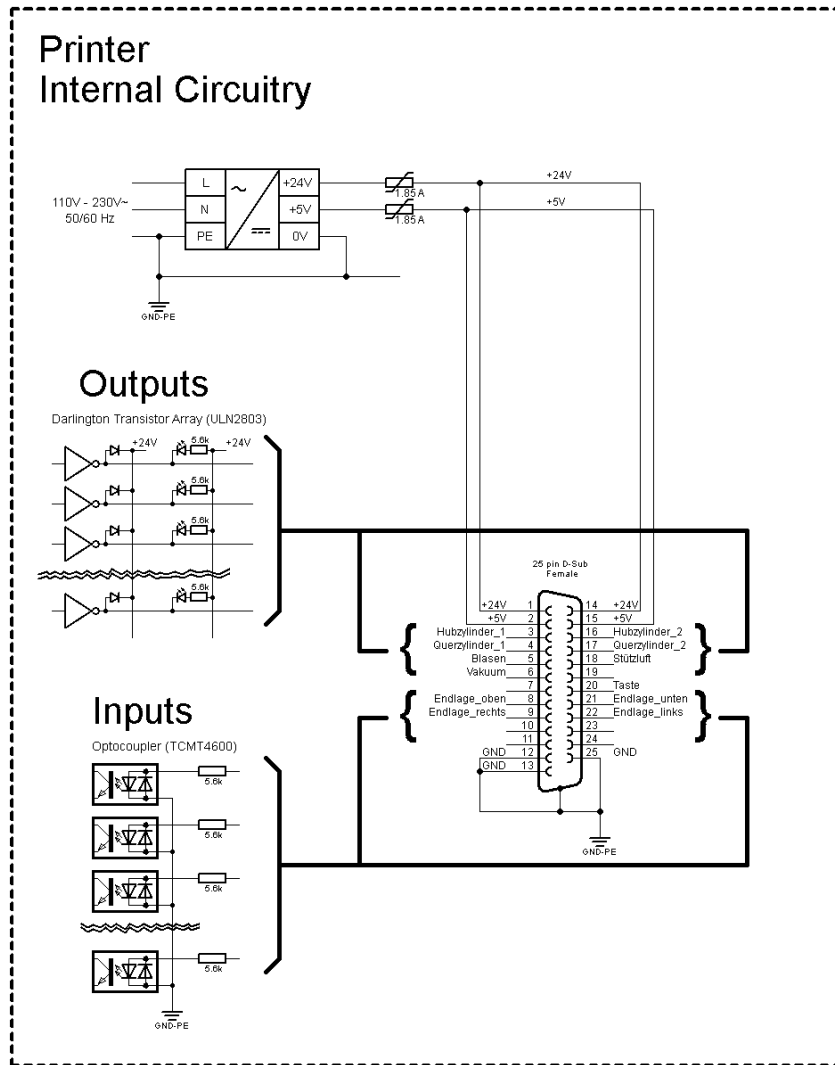

Figure 34

12.2 Pin assignment D-Sub bushing

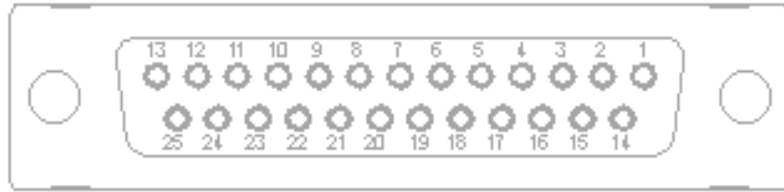

Figure 35

Signal assignment

| Pin | Signal | Pin | Signal | Description / Function |
|-----|---------------------|-----|---------------------|---|
| 1 | 24V | 14 | 24V | 24 Volt DC output for external use max 1 A. |
| 2 | 5V | 15 | 5V | 5 Volt DC output for external use max 1 A. |
| 3 | Stroke cylinder 1 | 16 | Stroke cylinder 2 | Outputs (open Collector) 24 V / 0,1 A |
| 4 | Lateral cylinder 1* | 17 | Lateral cylinder 2* | |
| 5 | Blow on | 18 | Supporting air | |
| 6 | Vacuum | 19 | | |
| 7 | | 20 | Switch | Digital inputs 24 V |
| 8 | Top end position | 21 | Bottom end position | |
| 9 | Right end position | 22 | Left end position | |
| 10 | | 23 | Vacuum control | |
| 11 | Pressure control | 24 | | |
| 12 | GND | 25 | GND | GND-PE |
| 13 | GND | | | |

* Option, on demand only

Technical data

| Connection plug | |
|--|---------------------------------------|
| Type | D-Sub connector 25 pin / connector |
| Producer/distributor | MPE Garry / Schukat |
| Order no. | LPBL25RZM |
| Output voltage (connected with GND-PE) | |
| + 24 V / 1 A | Fuse: Polyswitch / 30 V / 1.85 A |
| + 5 V / 1 A | Fuse: Polyswitch / 30 V / 1.85 A |
| Digital outputs | |
| Driver | ULN2803A (open Collector) |
| Voltage | 24 VDC |
| Current max | -0,1A |
| Impedance | Pull up 5,6 kΩ |
| Digital inputs | |
| Optocoupler | TCMT4600, CTR 80 % - 300 % |
| Voltage | 24 VDC |
| Impedance | 5,6 kΩ |
| Analogue inputs (optional, on demand only) | |
| OP | LMV393 |
| Voltage | 0..5 VDC |
| Impedance | >100 kΩ |

12.3 Examples

Example 1

Device connection to a machine with S7-300 SPS.

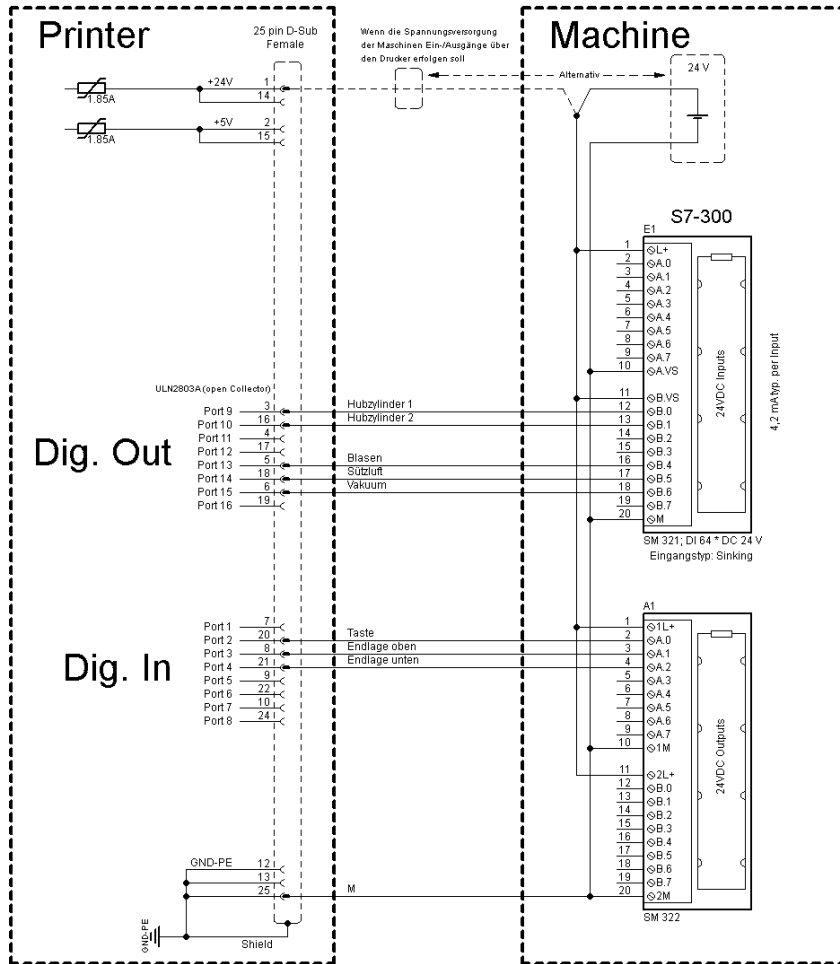

Figure 36

Example 2

Device connection to an applicator.

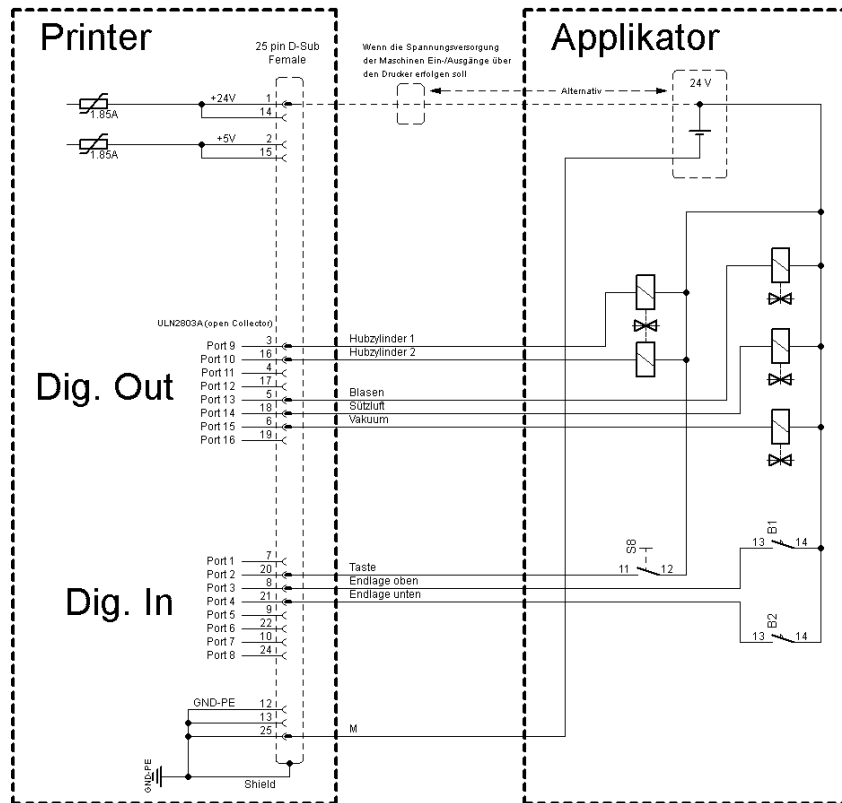

Figure 37

12.4 Precautions

When connecting a reed contact with a control input, the contact must have a switching capacity of min. 1 A in order to prevent the contact from sticking due to the inrush current. As an alternative, a suitable resistor can be connected in series.

If one of the printing system's internal voltages '+5 VDC EXT' or '+24 VDC EXT' is used, an external fuse e.g. 0.5 AF, should be additionally installed to protect the printing system electronics.

In the event of an inductive load, an antiparallel connected diode, for instance, must be used to discharge the induction energy.





In order to minimise the influence of leakage currents at control outputs, a resistor must, depending on what is connected, be installed in parallel with the load.

In order to avoid any damages to the printing system, the max. output currents must not be exceeded or outputs shorted.

13 Error Messages

13.1 Error Messages of the Printing System

In case an error occurred the printing system stops and the print order is interrupted. Information to causes and remedies of printing system errors e.g. *no label found* are to be taken from the printing system manual.

1. Clear the error.
2. Press the key  to synchronize the label feed.
3. Remove the peeled labels manually.
4. Press the key  to quit the error state.
5. Press the key  to continue the print order or press the key  to cancel the print order.

13.2 Error Messages of the Applicator

| Error message | Cause | Remedy |
|--------------------|--|---|
| Upper position | The upper position (start position) was not reached. | Check the final position switch for the start position and the compressed-air supply. Adjust the stroke timeout. |
| Lower position | The lower position (labelling position) was not reached. | Check the final position switch for the labelling position and the compressed-air supply. Adjust the stroke timeout. |
| Empty vacuum plate | The sensor does not recognize a label at the vacuum plate. | Check if all holes of the pad plate are covered from the label. Check the compressed-air supply. Check if the switching threshold of the vacuum sensor is correctly adjusted (see chapter 13.3, page 64). |
| Compressed air | No compressed air is available. | Check the compressed air supply. Check if the switching threshold of the pressure sensor is correctly adjusted (see chapter 13.3, page 64). |
| Print position | At print start the pad is not in printing position (upper pad position). | Check the correct function and position of the final position switch for the upper position (start position). Check the pneumati function. |

**CAUTION!**

The pad will immediately be moved in the starting position.

Danger of crushing to hand and fingers by the moving pad.

- ⇒ Do not reach into the zone of the moving pad.
- ⇒ Keep long hair, loose clothes and jewellery distant from the zone of the moving pad.
- ⇒ Danger of striking by the moving rods.
Do not reach or bend into the zone of the moving rods.

After error correction, the print of the label causing the error cannot be repeated without re-start of the print order.

Switch on the printing system and the display shows the main menu.

13.3 Troubleshooting pressure /vacuum control

Error: Empty vacuum plate



After verification that all holes in the pad plate are covered by the by the label and the pressure supply functions correctly, the switching threshold of vacuum sensor is to be set anew.

Press the key  to access the function menu.



Press the key  until the menu *Label applicator* is displayed.

Press the key  to select the menu.

Press the key  until the inputs and outputs are displayed.

Press the keys  and  so select the corresponding output for set/reset the output signals.

Press the keys  and  to set/reset the corresponding output.

Press the key  to move to output O₇ and press the key  (1 = On) to switch on the vacuum valve.

Place the label which is to be printed below the pad so that all suction holes are covered by the label. By the applied vacuum the label remains under the pad.

In case of correct operation, the input value I₅ should represent the value 1 (see display). Otherwise the switching threshold of vacuum sensor must be set with the right rotary potentiometer (B, see Figure 38) in that way that the switching threshold changed the value from 0 to 1. Turn the rotary potentiometer (B, Figure 38) clockwise and/or counterclockwise.

Remove the label from the pad. The input value I₅ should indicate the value 0. If a label is sucked again to the pad, the value should change to 1.

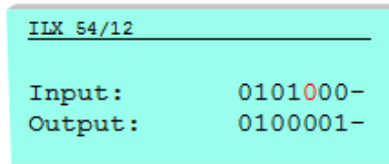

Switching limit vacuum sensor
Input I₅ = 0

Vacuum is switched On
(Output O₇ = 1)

The system recognizes that no
label is under the pad

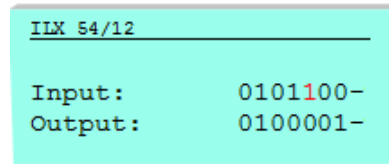

Switching limit vacuum sensor
Input I₅ = 1

Vacuum is switched On
(Output O₇ = 1)

The system recognizes that a
label is under the pad

Error: Compressed air

After verification that the compressed air supply functions correctly, the switching threshold of the pressure sensor must be set.

Press the key **F** to access the function menu.

Press the key until the menu *Label applicator* is displayed.

Press the key to select the menu.

Press the key until the inputs and outputs are displayed.

Press the keys and to select the corresponding output for set/reset the output signals.

Press the keys and to set/reset the corresponding output.

The air pressure is set to a minimum pressure of 2.5 bar. The input value I₄ should now represent the value 1 (see display). Otherwise the switching threshold of pressure sensor must be set with the left rotary (A, Figure 38) in that way that the switching threshold changed the value from 0 to 1. Turn the rotary potentiometer (A, Figure 38) clockwise and/or counterclockwise.

The air pressure is set to < 2.5 bar. The input value I₄ should now represent the value 0. If the air pressure is set to > 2.5 bar, the value should again change to 1.

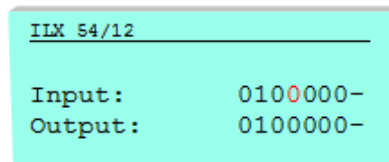

Switching limit pressure sensor
Input I₄ = 0

The system recognizes that the
minimum pressure of 2.5 bar is
not set

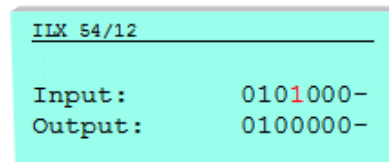

Switching limit pressure sensor
Input I₄ = 1

The system recognizes that the
working pressure is ≥ 2,5 bar

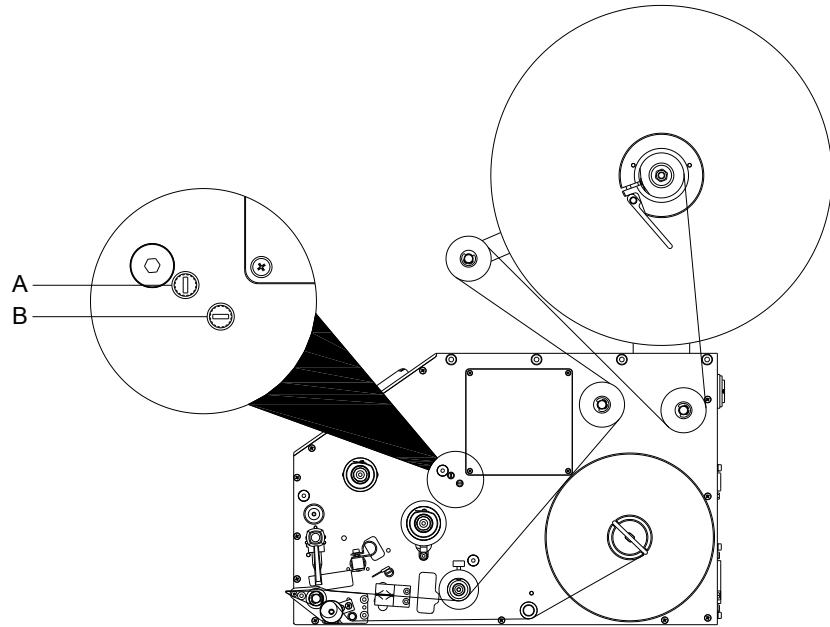
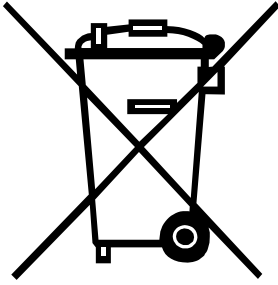

Figure 38

14 Environmentally-Friendly Disposal



Manufacturers of B2B equipment are obliged to take back and dispose of old equipment that was manufactured after 13 August 2005. As a principle, this old equipment may not be delivered to communal collecting points. It may only be organised, used and disposed of by the manufacturer. Valentin products accordingly labelled can therefore be returned to Carl Valentin GmbH.

This way, you can be sure your old equipment will be disposed of correctly.

Carl Valentin GmbH thereby fulfils all obligations regarding timely disposal of old equipment and facilitates the smooth reselling of these products. Please understand that we can only take back equipment that is sent free of carriage charges.

The electronics board of the printing system is equipped with a battery. This must only be discarded in battery collection containers or by public waste management authorities.

Further information on the WEEE directive is available on our website www.carl-valentin.de.

15 Index

A

| | |
|----------------------------|--------|
| applicator interface | 57 |
| examples | 61, 62 |
| precautions | 62 |

B

| | |
|-----------------------------|----|
| blow tube, adjusting..... | 44 |
| blowing air, adjusting..... | 51 |

C

| | |
|---------------------------------|--------|
| configuration | |
| operating mode..... | 31 |
| parameter | 31, 32 |
| connections, installation | 26 |
| control valves | 47, 48 |
| cover, removing | |
| electronics..... | 18 |
| pneumatic | 18 |

D

| | |
|--------------------------------|----|
| device overview | |
| front view | 14 |
| rear view | 15 |
| service unit..... | 16 |
| dispenser mode..... | 54 |
| D-SUB, signal assignment | 59 |
| D-SUB, technical data | 60 |

E

| | |
|---|--------|
| environmentally-friendly disposal | 67 |
| error messages | |
| applicator | 63, 64 |
| printing system..... | 63 |

F

| | |
|---------------------------------|--------|
| function menu (printing system) | |
| application modes..... | 33, 34 |
| blow time..... | 35 |
| cleaning time..... | 36 |
| delay lower end position | 36 |
| input/output | 38 |
| labelling signal | 37 |
| operating modes | 33 |
| pressure control | 35 |
| pressure time | 35 |
| quick-apply delay | 36 |
| roll on time | 36 |
| stroke timeout | 36 |
| support delay off | 34 |
| support delay on | 34 |
| test functions..... | 37 |
| transverse axis..... | 37 |
| vacuum control | 35 |
| vacuum delay on..... | 34 |
| waiting position | 35 |

| | |
|---------------------------------------|-----------|
| H | |
| holes (blow tube), opening | 43 |
| I | |
| installation to printing system | 22 |
| interface, applicator | 59 |
| instructions | 5 |
| intended use | 6 |
| L | |
| labels, apply | 13 |
| labels, loading | 53 |
| O | |
| operating conditions | 9, 10, 11 |
| options | |
| product sensor | 29 |
| quick apply | 27 |
| shock absorber | 28 |
| P | |
| pad | |
| adjusting | 43 |
| installation | 25 |
| movement speed | 49 |
| pad, aligning | |
| height adjustment | 41 |
| in print direction | 41 |
| side adjustment | 42 |
| pads, models | |
| blow pad | 17 |
| roll-on pad | 17 |
| tamp pad | 17 |
| pin assignment | 59 |
| printer internal circuitry | 58 |
| product description | 13 |
| product sensor | 29 |
| Q | |
| quick apply | 27 |
| S | |
| safety marking | 8 |
| scope of delivery | 21 |
| safety instructions | 7 |
| shock absorber | 28 |
| signal assignment, D-SUB | 59 |
| signal diagrams | |
| apply-print | 40 |
| print-apply | 39 |
| standard operation | 55 |
| stopper, adjusting | 45, 46 |
| supporting air, adjusting | 50 |
| T | |
| technical data | 19 |
| technical data, D-SUB | 60 |
| transfer ribbon, loading | 53 |

| | |
|------------------------|----|
| troubleshooting | |
| compressed air | 65 |
| pressure control | 64 |
| vacuum control | 64 |

U

| | |
|---|----|
| universal tamp pad | |
| piercing (standard tamp pad) | 23 |
| preparing (spring-mounted tamp pad) | 24 |

V

| | |
|-------------------------|----|
| vacuum, adjusting | 50 |
|-------------------------|----|



Carl Valentin GmbH
Neckarstraße 78 – 86 u. 94 . 78056 Villingen-Schwenningen
Phone +49 7720 9712-0 . Fax +49 7720 9712-9901
info@carl-valentin.de . www.carl-valentin.de